

Viblock

Brick System Specification

viblock.co.nz



Viblock Brick Cladding System Specification

This document has been prepared as a general specification for Viblock veneer products, including our 10 series and Kiwibrick ranges.

Every effort is made by Viblock to ensure the end user has a great product however we are only one step in the overall process. Each stage requires professional attention otherwise the result will not be to the desired standard. This includes selecting the desired product, ensure overall design complies with all building standards, engaging a professional to lay the product and finally sealing the product.

This document is a generic bricklaying specification for buildings between one and three stories with bricks either running or stack bond pattern. It has been developed with Kirk Roberts Consulting Engineers as an "Alternative Solution" to E2/AS1, applicable only when the appropriate reference is mentioned on design. E2/AS1 will apply if any aspect of the design has not been specifically addressed.

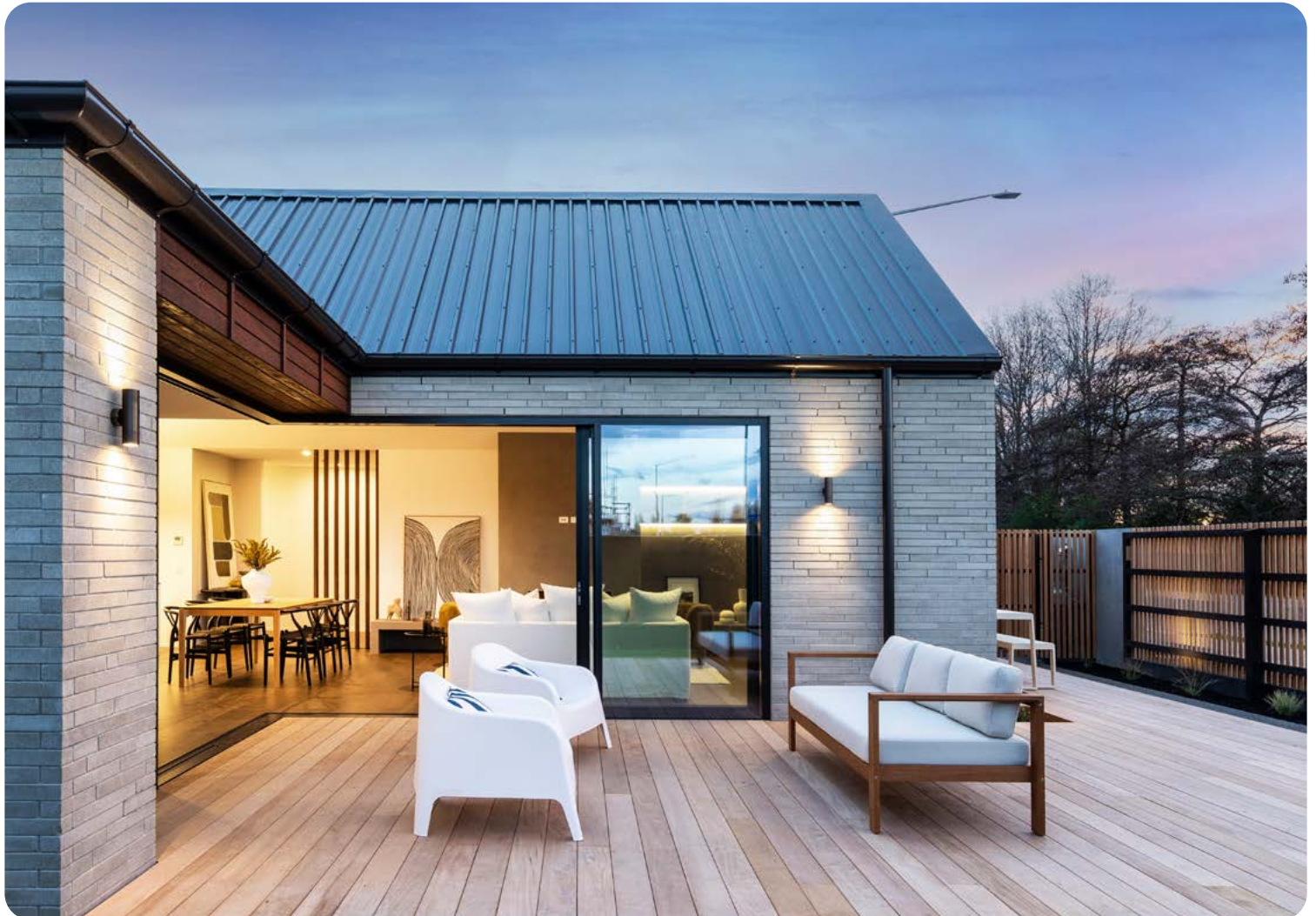

BRICKS

220 Series

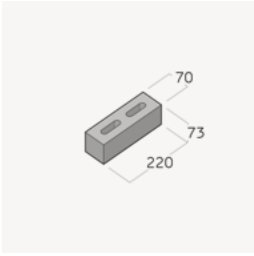

220
Standard

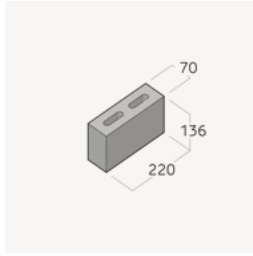

220
Double

220 Series bricks are available in Plain, Honed, Textured, and Rumbled finishes.

390 Series

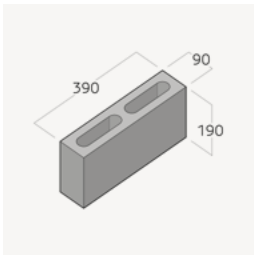

390
Standard

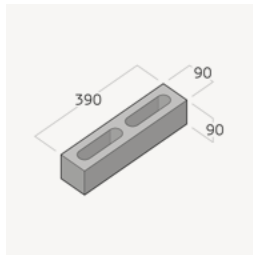

390
Half

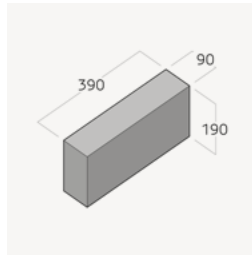

10.17 Solid (no core)
Also available rumbled

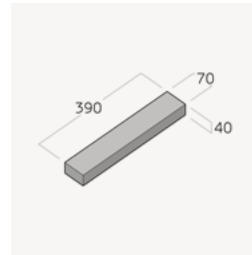

390
Slim 70

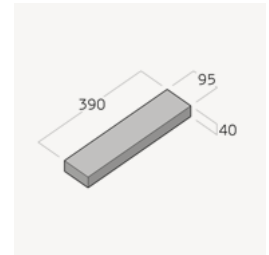

390
Slim 95

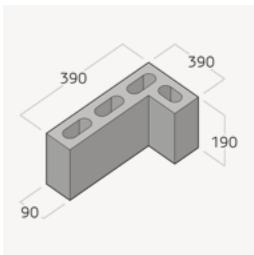

390
Corner

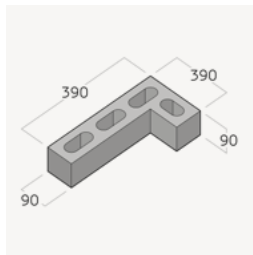

390
Half Corner

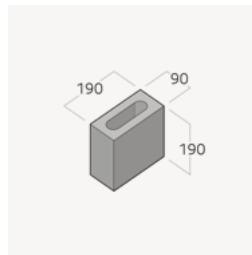

190
Standard

390 Standard bricks are available in Plain, Honed, Textured, and Rumbled finishes.

390 Series - Split

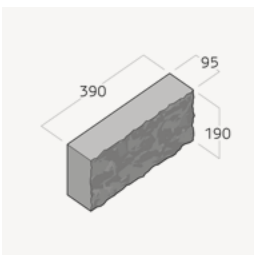

390
Standard SF

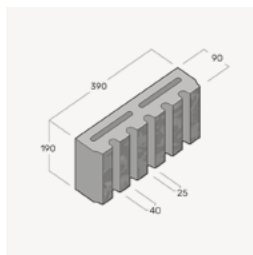

390
Fluted

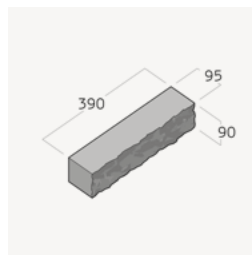

390
Half Summit Split

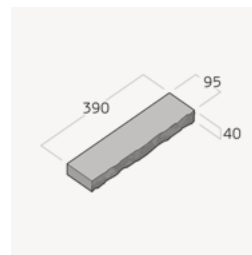

390
Slim Split

390 Series - Villa Veneer

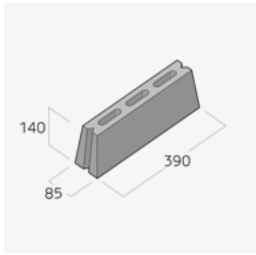

390 Villa
Standard Brick

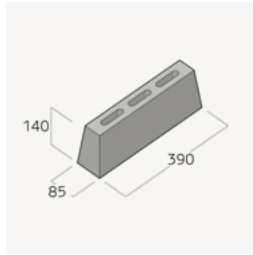

390 Villa
Window Brick

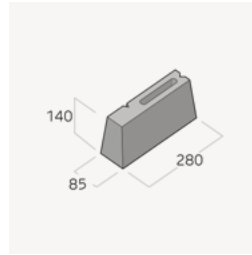

390 Villa
Ext. Corner RH
Pictured (LH Avail.)

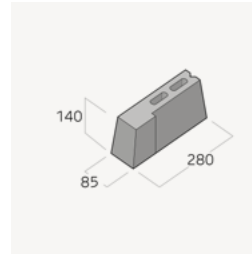

390 Villa
Int. Corner LH
Pictured (RH Avail.)

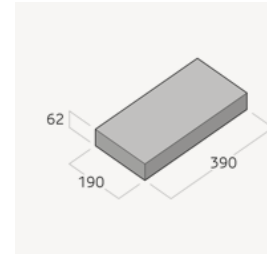

390 Sill
62mm

450 Series

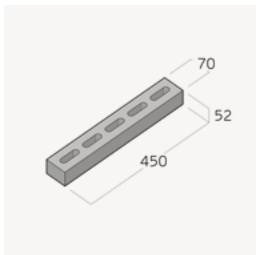

450
Slim

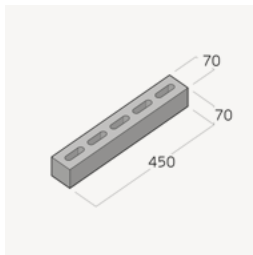

450
Half

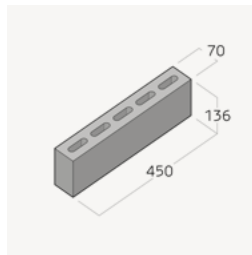

450
Standard

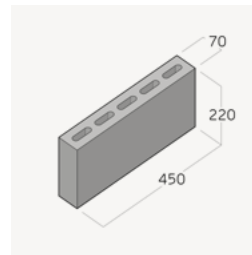

450
Double

450 Standard bricks are available in Plain, Honed, Textured, and Rumbled finishes.

| Series | Dimensions | Kgs/unit | Units/pallet | Tonne/pallet | Units/m ² |
|-------------------|------------------------------|----------|--------------|--------------|----------------------|
| 220 SERIES | | | | | |
| Standard | 220 x 73 x 70 | 1.9 | 660 | 1.25 | 53.0 |
| Double | 220 x 136 x 70 | 3.6 | 360 | 1.3 | 32.0 |
| 390 SERIES | | | | | |
| Standard | 390 x 190 x 90 | 10.6 | 150 | 1.62 | 12.5 |
| Corner | 390 x 190 x 90 mm (L-shaped) | 13.1 | 100 | 1.34 | 12.5 |
| Half High Corner | 390 x 90 x 90 mm (L-shaped) | 5.75 | 200 | 1.15 | 25.0 |
| Half | 390 x 90 x 90 | 4.8 | 300 | 1.47 | 25.0 |
| 390 Slim70 | 390 x 40 x 70 | 2.45 | 760 | 1.86 | 50 |
| 390 Slim95 | 390 x 40 x 95 | 3.2 | 600 | 1.92 | 50 |
| 190 Standard | 190 x 190 x 90 | 5.2 | 300 | 1.59 | 25 |
| 450 SERIES | | | | | |
| Standard | 450 x 136 x 70 | 7.3 | 192 | 1.4 | 16.0 |
| Double | 450 x 220 x 70 | 11.75 | 128 | 1.5 | 10.0 |
| Slim | 450 x 52x70 | 2.95 | 384 | 1.13 | 35.0 |
| Half | 450 x 70 x 70 | 3.8 | 384 | 1.45 | 28.0 |

VIBLOCK BRICK CLADDING SYSTEM – SPECIFICATION VB-B1

SPECIFIC DESIGN SPECIFICATION

GENERAL

The following is a specification used for the construction of single storey, running-bonded brick veneers.

- This document presents an ‘Alternative Solution’ to E2/AS1 applicable when Viblock concrete bricks, as mentioned in this document, are used as a masonry brick veneer.
- Unless otherwise noted then the requirements of E2/AS1 Masonry and NZS 4210 will apply.

This specification forms the basis of the following Viblock specifications:

- VB-B2: Two-storey running bonded specification.
- VB-B3: Three-storey running bonded specification.
- VB-S1: Single storey stack bonded specification.
- VB-S2: Two-storey stack bonded specification.
- VB-S3: Three-storey stack bonded specification.

RELEVANT DOCUMENTS

Relevant NZ Standards shall apply for all items NOT covered by this ‘Specific Design’ including the following:

- NZS 3604 Timber-framed buildings
- NZS 4210 Materials and workmanship
- NZS 4229 Masonry buildings not requiring Specific Design
- SNZ HB 4236 All standards relating to masonry veneers – summary
- NASH Standard Part 1 and Part 2

Note that current revisions of reference documents at the time of design, consent and construction are applicable and relevant.

In addition to a Viblock brick veneer being installed in accordance with this specific design specification, the following provisions of the NZ Building Code must also be met.

- B1 Structure
- B2 Durability
- C3 Spread of Fire
- E2 External Moisture
- F2 Hazardous Building Materials

LIMITATIONS

The designer shall ensure that Viblock brick veneer detailing, as presented within the Building Consent Plans and Specifications, complies with all aspects of this 'Specific Design Specification'. Plans submitted for Building Consent must be clearly marked and identify the use of Viblock brick veneers as follows;

“Viblock Brick Cladding System – Specification VB-B1 – no substitution”

The Viblock single storey running bond brick veneer shall be subject to the following limitations:

- Single storey buildings of either residential or commercial use designed in accordance with AS/NZS1170 for up to an importance level of 2.
- The building shall have a concrete slab-on-ground construction, either specifically designed by an Engineer or in compliance with NZS 3604 minimum requirements.
- The supporting structure shall be timber framed construction in accordance with NZS 3604, concrete block/precast in accordance with NZS 4229 or light structural framing in accordance with NASH Standards part 1 and 2. Alternatively, a specific engineering designed supporting structure may be adopted as designed and detailed by a suitably qualified engineer.
- All aspects regarding the installation of the brick veneer shall conform to the requirements of NZS 3604, NZS 4229 and NZS 4210.
- The maximum height for a single storey veneer is limited to 4m from the foundation. At a gable wall or pier (see figure 1 below), the maximum height may extend to 5.5m.
- Bricks shall be laid to a running-bond pattern permitting up to 5%, wall face area, to be Soldier Courses and Stack-Bonding.
- Veneer brick selection, size, thickness and weight, excluding the allowance for the addition of up to a 10mm thick cement plaster coating if specified, shall not exceed that provided within Table 1 below.
- Buildings may be situated in all wind zones up to and including 'Extra High' wind zone in accordance with NZS 3604.
- Residential buildings are to be situated within earthquake zones 1-3 in accordance with NZS 3604, commercial buildings shall have an assessed period of not more than 1.5s in accordance to NZS 1170.

Bricks

Brick types for which this specification is applicable are as follows:

Table 1 – Bricks applicable to this specification

| Bricks applicable to this specification | | | | |
|---|------------------|-------------------|-----------------------|-----------------------------|
| Viblock Brick Product | Size (LxHxW) | No/m ² | Weight (kg) Per brick | Weight (kg/m ²) |
| 220 Double (Dunstan) | 220 x 136 x 70mm | 32 | 3.6 | 125 |
| 220 Standard (Shotover) | 220 x 73 x 70mm | 56 | 1.9 | 120 |
| 450 Standard (Hawea) | 450 x 136 x 70mm | 16 | 7.2 | 120 |
| 450 Double (Whakatipu) | 450 x 220 x 70mm | 10 | 11.5 | 118 |
| 390 Standard | 390 x 190 x 90mm | 12.5 | 10.6 | 137 |
| 390 Half | 390 x 90 x 90mm | 25 | 4.8 | 128 |
| 390 Fluted | 390 x 190 x 90mm | 12.5 | 12.5 | 160 |
| 390 Standard - Split | 390 x 190 x 90mm | 12.5 | 13.8 | 177 |
| 450 Slim (Dart) | 450 x 52 x 72mm | 40 | 3.25 | 130 |
| 450 Half (Kawarau) | 450 x 70 x 70mm | 30 | 4.1 | 123 |
| 390 Slim 70 | 390 x 40 x 70mm | 50 | 2.45 | 125 |
| 390 Slim 95 | 390 x 40 x 95mm | 50 | 3.20 | 160 |

Note: Table 1 includes a 4% allowance for wastage in the number of bricks per m², for ordering purposes, add 15kg/m² for the addition of 10mm plaster finish.

BRICK VENEER CONSTRUCTION

Maximum Veneer Heights

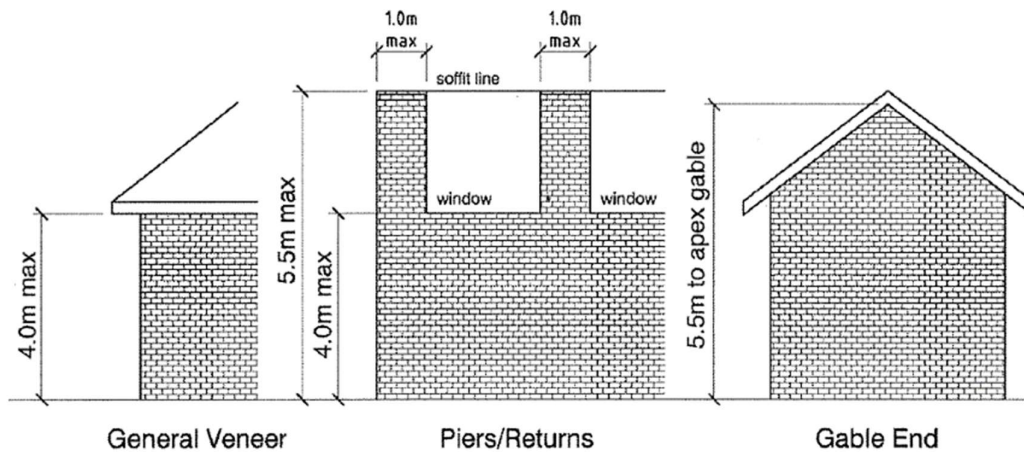

Figure 1 – Maximum veneer heights for single storey, running-bonded construction – diagram sourced from Clay Brick & Paver Manufactures association

Wall panels

- Brick wall panels may be laid to a maximum height of 4.0m without the addition of shelf angles or slip joints.

Gable Ends and Piers

- Gable end wall panels may be laid to a maximum height of 5.5m.

- Brick piers, of maximum width not exceeding 1.0m in width and not supporting loads from lintel shelf angles are not to exceed 5.5m in total height.

Supporting Structure

- The supporting structure shall be timber framed construction in accordance with NZS 3604, concrete block/precast in accordance with NZS 4229 or light structural framing in accordance with NASH Standards part 1 and 2. Alternatively, a specific engineering designed supporting structure may be adopted as designed and detailed by a suitably qualified engineer.

Rigid Air Barrier (RAB)

- Rigid air barriers may be placed either inside or outside of the timber framing in accordance with the manufacturer's installation recommendations.
- Where the RAB is placed on the outside of the supporting framing, the brick tie screw length shall increase to a minimum of length of 40mm.
- A minimum 40mm cavity shall be maintained.

Bracing

- Bracing requirements may be determined by using the prescribed tables in NZS 3604, NASH Standard or specifically calculated by a suitably qualified engineer.

Cavities

- The cavity between the masonry veneer and the exterior face of the supporting framing and/or rigid air board shall not be less than 40mm or more than 75mm wide.
- The cavity must be kept free of mortar droppings and any other obstruction.
- Washouts are to be installed every 10th brick and one on each corner.
- The cavity shall be ventilated to the outside by the provision of weep, or vent holes, at the base of the wall formed by removing mortar from the perpend joint at centres not exceeding 800mm to achieve a minimum of 1000mm² of weep/vent hole per linear metre.
- Install similar vent holes at the top of the wall, in the *second row of bricks* from the top, to match the bottom of the veneer panel, or leave a 10mm gap at the top of the veneer and the soffit board for ventilation.
- Pipes and services shall not be placed in the cavity other than those passing directly through the cavity to the exterior.

Mortar

The mortar used conform with the following

- Sand/cement ratio of 4:1. For sea spray zones and NZS 3604 corrosion zone D, the ratio should be increased to 3:1 sand/cement.
- All requirements as set out in NZS 4210.
- Manufactured and bagged, or site mixed mortar meeting the minimum specifications in accordance with NZS 4210 are acceptable.
- The same mortar must be used throughout the entire veneer.
- The minimum 28-day compressive strength of mortars used for veneer construction shall not be less than 12.5MPa.

Mortar Joints

- Mortar joints shall be as close to 10mm as possible with an acceptable tolerance of +/- 3mm.
- Maximum permitted joint thickness of 20mm may be accepted for the bottom mortar course in order to take up the permitted tolerances of the supporting concrete.
- All mortar joints shall be within ± 3 mm of the specified thickness.
- The maximum permitted raked depth is 6mm.
- All bed and perpend joints are to contain a full spread of mortar, any holes are to be remediated by filling with mortar.

Vertical control Joints

There are three options available for installing 'Control Joints'

- A vertical saw cut to a depth of 30mm, and filled with flexible sealant.
- A vertical or zig-zag 10mm gap with a foam backing rod and flexible sealant.
- A control joint in the location of the saw tooth slip joint.

Installation of alternative control joint

- The brick cores/recesses/frog shall be fitted with mortar and stuck off level with the top of the brick. This is to prevent the polythene layer from sagging into the cores/recesses/frog. At each control joint a thin layer of 150 micron polythene tape or similar shall be placed on top and at ends of each unit covering at least 75% of it's width. Mortar shall then be placed on the horizontal polythene bed and the end of the unit to be laid. The polythene bed and the end of the unit to be laid. The polythene creating a bond break horizontally and vertically in a "saw tooth" pattern.

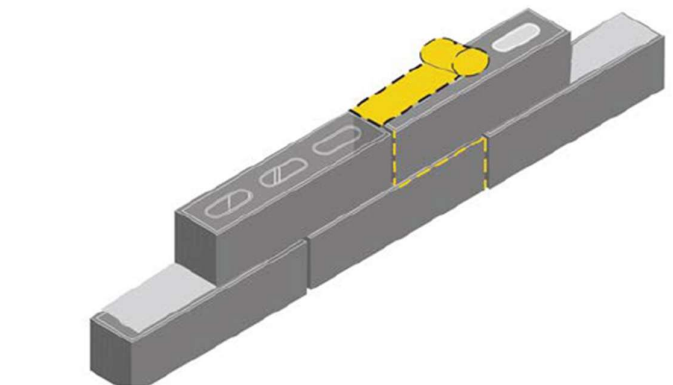

- This alternative control joint is suitable for all Viblock brick veneers except for plaster applications.

Location of Control Joints:

SNZ HB 4236, in accordance with NZS 4229, recommends control joints are installed at no greater than 6m centres. Where the veneer will not be subject to repeated cyclic wetting and drying or large changes in ambient temperature, it is possible to construct longer panels (typically up to 8.5m) using Viblock products. Refer to Viblock for further advice.

It is recommended that, where control joints are deemed necessary, these are installed in the following locations of the veneer:

- At T joints, within 600mm of the joint on the intersecting wall
- Within 600mm of one side of L shaped corners. Alternatively, the spacing of control joints on both sides of the corner may be restricted to 3.2m maximum
- At changes in wall height exceeding 600mm
- Window openings less than 2.0m wide – Control Joint one side (may be omitted where the above maximum control joint spacing conditions are met).
- Window openings greater than 2.0m wide – Control Joint both sides (one side only where the above maximum control joint spacing conditions are met, and provided a control joint is provided with 3m maximum of the opposite side of the opening).
- Where no openings are present, no greater than 6.0m spacing, or 8.5m where the conditions outlined above are satisfied.

Control joint locations shall be specified by the architect/client adhering to the above requirements. Where control joints are not installed in accordance with this specification it will cause the veneer installation to become non-compliant. *Viblock will not be responsible for any issues/failures (for example, cracking) which may arise as a result of failure to install control joints.*

Brick Tie Installation

All proprietary brick ties used in conjunction with Viblock brick veneers must comply with the requirements of AS/NZS 2699.1. The following requirements apply to all brick ties on Viblock brick veneers:

- Galvanised steel brick ties and screws in accordance with AS/NZS 2699.1 shall be used unless the building is within 500m of the high-water mark of the sea (corrosion zone D), in which case stainless steel grade 316 or 316L products shall be adopted.
- Screws, as specified by the proprietary tie supplier, with a minimum length of 35mm shall be used. If fixing through rigid air board the screw length shall be increased to 40mm min. Proprietary specified screws are typically 12g type 17.
- Brick ties are to have a minimum embedment length (to the bed joint) of at least half the width of the veneer.
- Brick ties shall be placed with a slope of 5° degrees down from the framing towards the masonry.
- IBP, EH Masons, MSL Ultimate brick ties or equivalent are to be used.

- If masonry block or pre-cast panels are being used to support the brick veneer, the tie fixings must be ICCONS Strike Mushroom Head 5mmx38mm stainless steel (STMH05038SS) or equivalent. Alternative fixings may be designed by a suitably qualified engineer.
- Where bricks are laid on a shelf angle, ensure the first row of ties is not more than 300mm or 2 courses, whichever is smaller, from the shelf angle.
- At all sides of openings, or at unsupported edges, including under an opening sill or at the top edge of a panel, the first row of ties shall be located no more than 300mm from the unsupported edge or opening.

Tie spacing requirements

Fixings to supporting structure; ties shall be fixed at the maximum spacings as per the following table:

Table 2 – Tie spacing

| Placement of Brick ties in Mortar Courses | | | |
|--|------------------------|---|---|
| Viblock Brick Product | Height of Brick | Horizontal fixings at 600mm crs. | Horizontal fixings at 400mm crs. |
| 220 Double (Dunstan) | 136mm | Every 3 rd course | Every 4 th course |
| 220 Standard (Shotover) | 73mm | Every 6 th course | Every 7 th course |
| 450 Standard (Hawea) | 136mm | Every 3 rd course | Every 4 th course |
| 450 Double (Whakatipu) | 220mm | Every 2 nd course | Every 3 rd course |
| 390 Standard | 190mm | Every 3 rd course | Every 3 rd course |
| 390 Half | 90mm | Every 5 th course | Every 6 th course |
| 390 Fluted | 190mm | Every 3 rd course | Every 4 th course |
| 390 Standard - Split | 190mm | Every 3 rd course | Every 4 th course |
| 450 Slim (Dart) | 52mm | Every 8 th course | Every 8 th Course |
| 450 Half (Kawarau) | 70mm | Every 6 th course | Every 6 th Course |
| 390 Slim 70 | 40mm | Every 8 th course | Every 8 th course |
| 390 Slim 95 | 40mm | Every 8 th course | Every 8 th course |

NOTE: Where ties are fixed to a precast concrete or masonry wall, horizontal spacings of 400mm or 600mm are to be used in accordance with Table 2, when fixed to timber or steel framed substructure stud spacings will be 400mm or 600mm as stated to achieve the horizontal spacing requirements.

Masonry brick In-Joint reinforcement

In-joint reinforcement where required by specific engineering design shall be steel hot-dipped galvanised after fabrication or 316 stainless steel and shall be fully embedded within the mortar joint with a minimum side cover of 15mm.

Openings

Window and Door sills

- It is *recommended* (unless detailed on the project plans otherwise) that the slope of sill bricks should be 15 degrees achieved with mortar packing as per SNZ HB 4236.
- It is *recommended* that bricks overhang the sills by 30-50mm with a +/- 5mm maximum tolerance.
- All window sills are to be consistent throughout the project.

- Provide flashing across the tops of all openings, installation as per the requirements of SNZ HB 4236.

Lintels

Openings with brick veneer above shall be spanned by mild steel angel lintels, protected against corrosion in accordance with SNZ HB 4236;

- For durability requirements 600g/m² (85µm average thickness) galvanised coating or 304 stainless steel can generally be adopted. For sea spray zones 316 or 316L stainless steel is to be adopted. An alternative of using hot-dip galvanized with an epoxy powder coating to NZS 3604 may also be considered within a sea spray zone. Specific protection is required for geothermal hot spots.
- Where holes are cut after steel has been galvanised, these are to be sprayed using 'cold galvanising' spray for protection.

Lintels may be installed by the methods as described below:

Seated lintels

- Lintels shall have at least 100mm of seating onto the veneer at each end of an opening for spans up to 2m, and 200mm at each end for spans greater than 2m.
- Steel lintels must be kept 20mm behind the front face of the brick veneer.
- The maximum height of veneer above a shelf angle is the average height supported by the lintel.

The following lintels may be used with this method:

Table 3 – Steel lintel sizes for the traditional method

| Maximum lintel span (mm) | Thickness of veneer (mm) | | | | | |
|-----------------------------------|---|------------|------------|-----------|------------|------------|
| | 70 | | | 90 | | |
| | Average Maximum height of veneer supported (mm) | | | | | |
| | 350 | 700 | 2000 | 350 | 700 | 2000 |
| 800 | 60x60x6L | 60x60x6L | 60x60x6L | 60x80x6L | 60x80x6L | 80x80x6L |
| 2000 | 60x60x6L | 60x60x6L | 60x60x6L | 60x80x6L | 60x80x6L | 80x80x6L |
| 2500 | 60x60x6L | 80x80x6L | 80x80x6L | 80x80x6L | 80x80x6L | 80x80x6L |
| 3000 | 80x80x6L | 80x80x6L | 125x75x6L | 80x80x6L | 80x80x8L | 90x90x10L |
| 3500 | 80x80x6L | 80x80x6L | 125x75x6L | 80x80x8L | 90x90x10L | 125x75x10L |
| 4000 | 80x80x8L | 125x75x6L | 125x75x10L | 80x80x10L | 125x75x6L | 150x90x10L |
| 4500 | 125x75x6L | 125x75x10L | 125x75x12L | 125x75x6L | 125x75x10L | 150x90x12L |
| 4800 | 125x75x6L | 125x75x10L | 125x75x12L | 125x75x6L | 125x75x10L | 150x90x12L |

Note: Size of angle, minimum steel grade 250MPa, equivalent or greater sizes in stainless steel may be used where required. Table extracted from NZBC E2.

For alternative materials or spans outside those permitted, specific engineering design shall be required. Lintels shall be kept completely free of the support structure.

Shelf angles

Shelf angles are **NOT** lintels and shall not be relied on to span over any opening.

- Shelf angles shall be direct-fixed to the supporting substructure or a timber/steel structural lintel.
- The maximum height of veneer above a shelf angle shall be limited to 4m.
- Shelf angles and their associated fixings are to be assessed by a suitably qualified engineer. Shelf angles are typically installed horizontally however they may be installed at up to a maximum slope of 60 degrees or less to the horizontal.
- Shelf angles may be a mild steel angle grade 250MPa or an alternative material or system as per the requirements of the engineer.
- The fixings back to the support structure are to be assessed by a suitably qualified engineer.

The following table may be used for the size of typical shelf angles:

Table 4 – Shelf angle sizing:

| Shelf angle sizes (Galvanized) | |
|--------------------------------|---|
| Cavity Width (mm): | Size of Angle (V x H x t), Min Grade 250MPa |
| 40-55mm | 75x100x6mm |
| 60-75mm | 75x125x6mm |

Note: Equivalent or greater sizes in stainless steel may be used where required. The above angles are orientated with the 75mm leg vertically against the substructure with M10 fixings at no greater than 400mm centres. M10 coach bolts or M10x75mm coach screws shall be adopted to suit the substructure. Alternative fixing sizes and centres may be provided by a suitably qualified engineer, provided the maximum 400mm crs is adhered to.

- Where shelf angles are installed above a deck area, ensure there is a 35mm clearance under the angle.
- Bricks may be laid directly onto the angle. Where bricks have been cut (as in the case with a sloping angle), a 10mm mortar bed is recommended.

Flashings

Head, jamb, and sill flashings around all openings are to be installed as acceptable solution E2/AS1, paragraphs 9.24 and figure 73C (shown below).

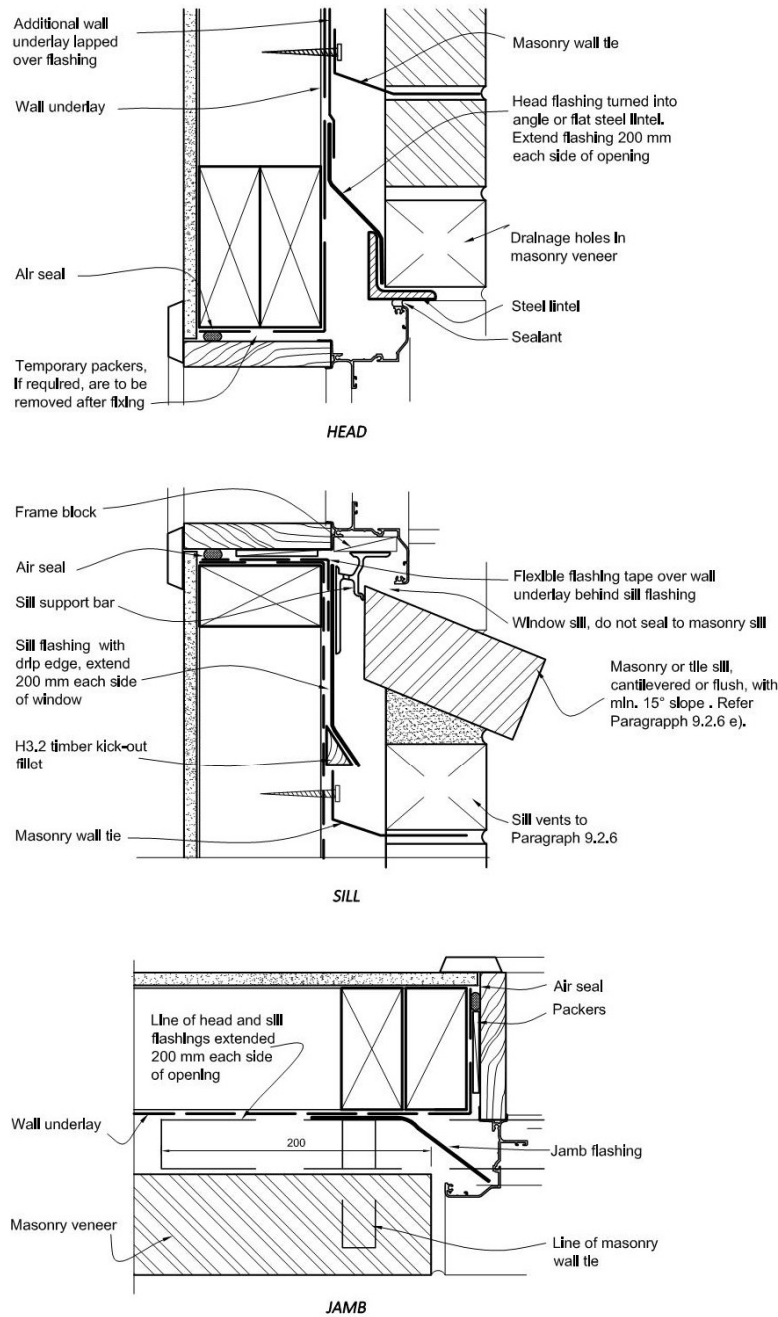

- NOTE:
- (1) Window profile to be selected to achieve cover shown in details.
 - (2) Architraves are shown for consistency only, detail may be used with rebated liner.
 - (3) Window support brackets required conforming with EM6 and Paragraph 9.1.10.5 not shown on detail, refer Figure 72B.

Figure 2 – Figure 73C of acceptable solution E2/AS1; recommended head, sill, and jamb flashing detail.

BRICKLAYING REQUIREMENTS:**Brick Delivery and protection**

The 'bricklayer' is responsible for checking that the correct bricks and quantity have been delivered to site, that the quality of product delivered is acceptable and to ensure that all product is derived from a single one batch number. Identification of potential issues, or quality of product regarding bricks supplied shall be raised immediately with the project manager and is to be taken up with the supplier prior to laying any bricks. Viblock do not accept responsibility for quality of brick once they have been laid.

All bricks supplied to site are to be suitably protected from adverse elements such as rain, dust and shall be protected from other damage, such as impact such as not to damage the veneer or any bricks. Any damaged veneer or bricks are to be replaced at the bricklayer's expense.

Workmanship

All bricklaying is to be undertaken by a licensed trade professional with appropriate LBP (Licensed Building Practitioner) or supervised by an LBP. The LBP will be responsible for the brick veneer, and for certifying that the veneer meets all the requirements of this document and/or E2/AS1 and NZS 4210. Bricklaying shall be in accordance with the design bond pattern.

Inclement weather

Laying of bricks shall not be undertaken in inclement weather conditions, this shall include, but not be limited to adverse rain events, high winds and or when the air temperature exceeds 25 degrees Celsius and/or hot drying winds are present. Newly laid brick veneer mortar must be properly cured for a minimum of the first 24 hours and recommended for several days duration. Curing shall be by adding moisture to the veneer in addition to protecting it from direct sunlight and drying winds.

Tolerances

For masonry veneer construction all bricks are to be laid within the tolerances given in Table 2.2 of NZS 4210 (refer Table 5 below).

Table 5 – Table 2.2 of NZS 4210; acceptable maximum tolerances for the brick veneer

Table 2.2 – Maximum tolerances

| Item | Tolerances |
|--|-------------------------------|
| Deviation from the position shown on plan for a building more than one storey in height | 15 mm |
| Deviation from vertical within a storey | 10 mm per 3 m of height |
| Deviation from vertical in total height of building | 20 mm |
| Relative vertical displacement between masonry courses (a) Nominated fair face (one side only) (b) Structural face | 3 mm 5 mm |
| Relative displacement between loadbearing walls in adjacent storeys intended to be in vertical alignment | 5 mm |
| Deviation from line in plan (a) In any length up to 10 m (b) In any length over 10 m | 5 mm 10 mm total |
| Deviation of bed joint from horizontal (a) In any length up to 10 m (b) In any length over 10 m | 5 mm 10 mm total |
| Average thickness of bed joint, cross joint, or perpend | ± 3 mm on thickness specified |

NOTE – Tolerances shall not breach minimum cavity widths.

Bonding of bricks

- The bricks, unless otherwise specified, are to be laid running bond unless otherwise specified.
- All perpend joints are to be in vertical alignment (+/- 5mm).
- Stack bonding is not permitted in NZS 3604 and NZS 4229, any 'Stack-bonding' requires 'Specific Design', refer to Viblock specifications VB-S1, VB-S2, & VB-S3 (as appropriate).

Blending of bricks

- As is well known by Architects and Builders alike, the artistic, and aesthetic qualities of brick wall panels are best achieved and enhanced by paying attention to blending of bricks. This may be achieved by selecting bricks into a wheelbarrow at random along a heap of bricks, thus "mixing" the bricks. To achieve maximum blending effect in your wall panels, you should work with 5 or 6 pallets packs at the same time, taking from each pack in turn.
- Laying of bricks is to stop immediately if it becomes apparent that these will run out before completion. This will allow new bricks, which may be from a different batch, to be blended in properly.

Post construction maintenance

- Viblock recommends the bricks are cleaned annually or as required depending on conditions. It is important to **not use high pressure (water blasters)** as they can mark the bricks. A low pressure water wash with a natural detergent and soft brush is recommended.

Efflorescence (Salting)

The term efflorescence is used to describe white deposits which sometimes form on the surface of cementitious products, concrete or masonry walls

- Efflorescence is a naturally occurring phenomena associated with all concrete products.
- To reduce the chance of efflorescence occurring Viblock recommend the following steps are taken:
 - Products must be stored correctly before laying.
 - Laying of bricks should be completed by a licensed trade professional.
 - Sealing should also be carried out by a trade professional.
- If efflorescence is found on the bricks the salts can be removed by dry brushing, if still present a light acidic wash in accordance with the cleaning recommendation above will remove the affected area. Refer to suppliers for application details.

Sealing the Veneer

- Viblock recommends all products exposed to weather are sealed to ensure and long-lasting, high durability finish. Refer to sealer suppliers for application details.

Inspections and Completion:

- The LBP will be responsible for the brick veneer, and for certifying that the veneer meets all the requirements of this document and/or E2/AS1 and NZS 4210.
- A half-height inspection is to be called for at the appropriate times as the job progresses.
- Inspection to ensure that all flashings have been installed correctly, and inspected, prior to being covered by the brickwork.
- Inspection upon completion of works.
- Upon acceptable completion the veneer is to be 'Certified' in the Record of Works, held by the appropriate building authority, as compliant with this Specification: VB-B1, upon completion by a Licenced Building Practitioner for Bricklaying.

Plastering Viblock veneers

- Use a professional who has experience plastering concrete surfaces, 10mm maximum plater thickness.

TECHNICAL SUPPORT

Should you require any technical support on the Viblock Brick Veneer System, please contact Viblock on:

T: (03) 343 0394

Email: sales@viblock.co.nz

Website: <https://www.viblock.co.nz/contact-us/>



New Zealand
Institute of Architects
Incorporated



Building Code Clause(s) B1

PRODUCER STATEMENT – PS1 – DESIGN

ISSUE: 06

(Guidance on use of Producer Statements is available at www.engineeringnz.org)

ISSUED BY: **KIRK ROBERTS Consulting Ltd.**
(Design Firm) PROJECT NO: 2020853

TO: **Viblock**
(Owner/Developer)

TO BE SUPPLIED TO: **Relevant Territorial Authority**
(Building Consent Authority)

IN RESPECT OF: **Single storey running bonded brick veneer specification as per the attached documentation**
'VIBLOCK BRICK CLADDING SYSTEM – SPECIFICATION VB-B1'
(Description of Building Work)

AT: **Locations throughout New Zealand**
(Address)

We have been engaged by the owner/developer referred to above to provide **Structural Engineering Design** services in respect of the requirements of Clause(s) **B1/VM1** of the Building Code for All or Part only (as specified in the attachment to this statement), of the proposed building work.

The design carried out by us has been prepared in accordance with:

- Compliance Documents issued by the Ministry of Business, Innovation & Employment **B1/VM1** or
(verification method / acceptable solution)
- Alternative solution as per the attached schedule: _____

The proposed building work covered by this producer statement is described on the attached specification titled **'VIBLOCK BRICK CLADDING SYSTEM – SPECIFICATION VB-B1 revF'** and dated **14th August 2025**

On behalf of the Design Firm, and subject to:

- (i) All proprietary products meeting their performance specification requirements.
- (ii) Up to **'Extra High'** wind zone in accordance with NZS3604: 2011.
- (iii) Maximum site hazard factor **Z = 0.4** in accordance with NZS1170.5: 2004.
- (iv) **Structural design loads are based on a 50 year design life and Importance Level 2 structure (normal structures and structures not in other importance levels) as defined in AS/NZS 1170.0 2004 clause 3.3.**
- (v) **Unless specifically noted, all structural elements must comply with the relevant New Zealand design code such as NZS 3604, NZS 4229, NZS 2699, NZS 4210, and NZS HB 4236.**
These elements include, but are not limited to: brick ties, mortar strength, brick strength, and bond between the brick and mortar
Viblock brick products shall be manufactured to the requirements of NZS 4455.
- (vi) **This certificate does not cover weather-tightness, nor the stability, suitability or potential liquefaction of the site.**
- (vii) **This Producer Statement is valid for a building consent issued within 1 year from the date of issue.**
- (viii) **Inspections of the building are to be undertaken by the Building Consent Authority (council).**



New Zealand Institute of Architects Incorporated



I believe on reasonable grounds that a) the building, if constructed in accordance with the drawings, specifications, and other documents provided or listed in the attached schedule, will comply with the relevant provisions of the Building Code and that b), the persons who have undertaken the design have the necessary competency to do so. I also recommend the following level of construction monitoring/observation: (Refer note above)

CM1 CM2 CM3 CM4 CM5 (Engineering Categories) or as per agreement with owner/developer (Architectural)

I, **Craig Allan Manssen** am: CPEng **161576 #**
(Name of Design Professional)

Reg Arch #

I am a Member of: Engineering New Zealand NZIA and hold the following qualifications: **B.E.(Hons), CMEngNZ, CPEng**
The Design Firm issuing this statement holds a current policy of Professional Indemnity Insurance no less than \$200,000*.
The Design Firm is a member of ACENZ:

SIGNED BY **Craig Allan Manssen** ON BEHALF OF **Kirk Roberts Consulting Engineers Ltd.**

Digitally signed by C A Manssen (Design Firm)
DN: cn=NZ, e=craigm@kirkroberts.co.nz,
o=Kirk Roberts, ou=Kirk Roberts, cn=C
A Manssen
Location: New Zealand
Reason: I am approving this document
Contact Info: 0222999886
Date: 2025.08.14 14:53:36+12'00'

Date: **14 August 2025** (signature).....

Note: This statement shall only be relied upon by the Building Consent Authority named above. Liability under this statement accrues to the Design Firm only. The total maximum amount of damages payable arising from this statement and all other statements provided to the Building Consent Authority in relation to this building work, whether in contract, tort or otherwise (including negligence), is limited to the sum of \$200,000.*

This form is to accompany **Form 2 of the Building (Forms) Regulations 2004** for the application of a Building Consent.

THIS FORM AND ITS CONDITIONS ARE COPYRIGHT TO ACENZ, ENGINEERING NEW ZEALAND AND NZIA

VIBLOCK BRICK CLADDING SYSTEM – SPECIFICATION VB-B2

TWO STOREY RUNNING BONDED SPECIFICATION

GENERAL

The following is a specification used for the construction of two-storey, running-bonded brick veneers.

- This document presents an ‘Alternative Solution’ to E2/AS1 applicable when Viblock concrete bricks, as mentioned in this document, are used as a masonry brick veneer.
- This document is to be read in accordance with the pre-requisite Viblock brick cladding system specification VB-B1. Items not covered in this specification must comply with the specific design bricklaying specification for Viblock concrete bricks, Specification VB-B1.

Should a requirement in this document conflict with VB-B1, this specification, Specification VB – B2, is to apply.

LIMITATIONS

The designer shall ensure that Viblock brick veneer detailing, as presented within the Building Consent Plans and Specifications, complies with all aspects of this ‘Specific Design Specification’. Plans submitted for Building Consent must be clearly marked and identify the use of Viblock brick veneers as follows;

“Viblock Brick Cladding System – Specification VB-B2 – no substitution”

The Viblock two-storey running bonded brick veneer shall be subject to the limitations outlined in Specification VB-B1, with the following exceptions:

- Up to a 3kPa floor loading.
- A maximum of two-storey construction.
- Limited to a maximum calculated risk score of 20 in accordance with NZBC Acceptable Solution E2/AS1 Table 2.
- Where timber studs are used as the support structure, a maximum stud spacing of 400mm shall apply.
- Maximum veneer height of veneer above adjacent finished ground level of 7.5m for straight vertical panels and extended to 10.0m at the apex of a gable end or a pier of no more than 1.0m width.

Bricks

Brick types for which this specification is applicable are as follows:

Table 1 – Bricks applicable to this specification

| Bricks applicable to this specification | | | | |
|---|------------------|-------------------|-----------------------|-----------------------------|
| Viblock Brick Product | Size (LxHxW) | No/m ² | Weight (kg) Per brick | Weight (kg/m ²) |
| Dunstan | 220 x 136 x 70mm | 32 | 3.6 | 125 |
| Shotover | 220 x 73 x 70mm | 56 | 1.9 | 120 |
| Hawea | 450 x 136 x 70mm | 16 | 7.2 | 120 |
| Wakatipu | 450 x 220 x 70mm | 10 | 11.5 | 118 |
| Viblock 10 Series | 390 x 190 x 90mm | 12.5 | 10.6 | 137 |
| Viblock 10 Series – Half High | 390 x 90 x 90mm | 25 | 4.8 | 128 |
| Viblock 10 Series - Fluted | 390 x 190 x 90mm | 12.5 | 12.5 | 160 |
| Viblock 10 Series - Split face | 390 x 190 x 90mm | 12.5 | 13.8 | 177 |
| Dart | 450 x 52 x 72mm | 40 | 3.25 | 130 |
| Kawarau | 450 x 70 x 70mm | 30 | 4.1 | 123 |
| Nevis 70 | 390 x 40 x 70mm | 50 | 2.45 | 125 |
| Nevis 95 | 390 x 40 x 95mm | 50 | 3.2 | 160 |

Note: Table 1 includes a 4% allowance for wastage in the number of bricks per m², for ordering purposes, add 15kg/m² for the addition of 10mm plaster finish.

BRICK VENEER CONSTRUCTION

Maximum Veneer Heights

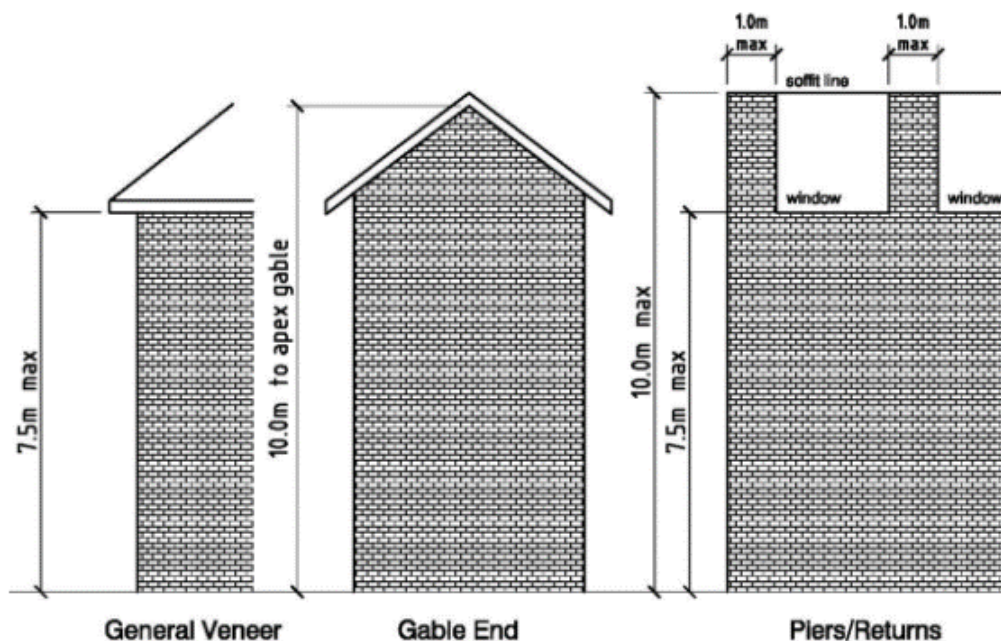

Figure 1 – Maximum Veneer Heights for two-storey running bond construction– diagram sourced from Clay Brick & Paver Manufactures association

Wall Panels

- Brick wall panels may be laid to a maximum height of 7.5m without the addition of shelf angles or slip joints.

Gable Ends and Piers

- Gable end wall panels may be laid to a maximum height of 10m.
- Brick piers, of maximum width not exceeding 1.0m in width and not supporting loads from lintel shelf angles are not to exceed 10m in total height.

Supporting structure

- The supporting structure shall be timber framed construction in accordance with NZS 3604, concrete block/precast in accordance with NZS 4229 or light structural framing in accordance with NASH Standards part 1 and 2. Alternatively, or where support structure deviates from these codes a specific engineering designed supporting structure may be adopted. Supporting structure to be designed and detailed by a suitably qualified engineer.

Brick Cavity

The cavity shall comply with the requirements noted in Specification VB-B1.

Brick Tie Installation

Brick ties shall comply with the requirements noted in Specification VB-B1, with the exception of the spacing requirements outlined below:

Brick tie spacing

Brick ties are to be fixed to supporting structure at a maximum horizontal spacing of 400mm, and vertically depending on the height of the brick as per table below. The upper most line of ties shall be installed at the first mortar bed joint below the top of the wall.

Table 2 – Tie spacing

| Placement of Brick ties in Mortar Courses | | |
|--|------------------------|---|
| Viblock Brick Product | Height of Brick | Horizontal fixings at 400mm crs. |
| Dunstan | 136mm | Every 3 rd course |
| Shotover | 73mm | Every 5 th course |
| Hawea | 136mm | Every 3 rd course |
| Wakatipu | 220mm | Every 2 nd course |
| Viblock 10 Series | 190mm | Every 2 nd course |
| Viblock 10 Series – Half High | 90mm | Every 5 th course |
| Viblock 10 Series - Fluted | 190mm | Every 2 nd course |
| Viblock 10 Series - Split face | 190mm | Every 2 nd course |
| Dart | 52mm | Every 8 th course |
| Kawarau | 70mm | Every 6 th course |
| Nevis 70 | 40mm | Every 8 th course |
| Nevis 95 | 40mm | Every 8 th Course |

Joint Reinforcement

- Install one row of bed joint reinforcement at $4\text{m} \pm 100\text{mm}$ above the bottom course.
- Install further rows of bed joint reinforcement, spaced $800\text{mm} \pm 100\text{mm}$ apart, above this level.
- Bed joint reinforcement is to be placed in mortar joints that do not contain brick ties.
- Bed joint reinforcement to be MASONS 4.0mm Bricklock STR and CNR galvanised or stainless-steel joint reinforcement or equivalent, as appropriate for the site exposure zone (refer NZS 3604).
- Where a gable exists on top of the veneer panel, install a further two rows of bed joint reinforcement, at the same spacing, into the gable.
- Bed joint reinforcement is not required within piers above the veneer panel.

Lintels

Lintels shall comply with the requirements noted in Specification VB-B1, with the following exceptions:

- Seated lintels may only be used over openings in the upper level of a two-storey building.
- Seated lintels may not be used over a skirt roof (use of seated lintels over an opening above a skirt roof is permitted).

Shelf Angles

In addition to the requirements set out in Specification VB-B1, shelf angles may be installed above skirt roofs.

- The architect/engineer is to ensure an adequate support structure for fixing of the shelf angle.
- The maximum veneer panel height above a shelf angle over a skirt roof is to be 4m, measured as shown in Figure 2 below.

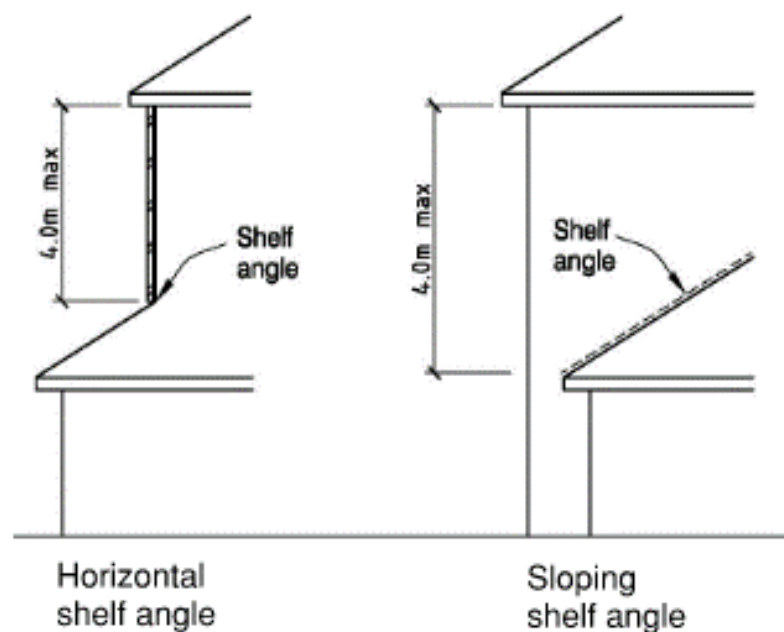

Figure 2 – Shelf Angles– diagram sourced from Clay Brick & Paver Manufactures association

TECHNICAL SUPPORT

Should you require any technical support on the Viblock Brick Veneer System, please contact Viblock on:

T: (03) 343 0394

Email: sales@viblock.co.nz

Website: <https://www.viblock.co.nz/contact-us/>



New Zealand
Institute of Architects
Incorporated



Building Code Clause(s) B1

PRODUCER STATEMENT – PS1 – DESIGN

ISSUE: 06

(Guidance on use of Producer Statements is available at www.engineeringnz.org)

ISSUED BY: **KIRK ROBERTS Consulting Ltd.**
(Design Firm) PROJECT NO: 2020853

TO: **Viblock**
(Owner/Developer)

TO BE SUPPLIED TO: **Relevant Territorial Authority**
(Building Consent Authority)

IN RESPECT OF: **Two-storey running bonded brick veneer specification as per the attached documentation**
'VIBLOCK BRICK CLADDING SYSTEM – SPECIFICATION VB-B2'
(Description of Building Work)

AT: **Locations throughout New Zealand**
(Address)

We have been engaged by the owner/developer referred to above to provide **Structural Engineering Design** services in respect of the requirements of Clause(s) **B1/VM1** of the Building Code for All or Part only (as specified in the attachment to this statement), of the proposed building work.

The design carried out by us has been prepared in accordance with:

- Compliance Documents issued by the Ministry of Business, Innovation & Employment **B1/VM1** or
(verification method / acceptable solution)
- Alternative solution as per the attached schedule: _____

The proposed building work covered by this producer statement is described on the attached specification titled **'VIBLOCK BRICK CLADDING SYSTEM – SPECIFICATION VB-B2 revF'** and dated **14th August 2025**

On behalf of the Design Firm, and subject to:

- (i) All proprietary products meeting their performance specification requirements.
- (ii) Up to **'Extra High'** wind zone in accordance with NZS3604: 2011.
- (iii) Maximum site hazard factor **Z = 0.4** in accordance with NZS1170.5: 2004.
- (iv) Structural design loads are based on a **50 year design life** and Importance **Level 2 structure** (normal structures and structures not in other importance levels) as defined in AS/NZS 1170.0 2004 clause 3.3.
- (v) Compliance with pre-requisite document **'VIBLOCK BRICK CLADDING SYSTEM – SPECIFICATION VB-B1'**
- (vi) Unless specifically noted, all structural elements must comply with the relevant New Zealand design code such as **NZS 3604, NZS 4229, NZS 2699, NZS 4210, and NZS HB 4236**.
These elements include, but are not limited to: **brick ties, mortar strength, brick strength, and bond between the brick and mortar.**
- (vii) Viblock brick products shall be manufactured to the requirements of **NZS 4455**.
- (viii) **This certificate does not cover weather-tightness, nor the stability, suitability or potential liquefaction of the site.**
- (ix) **This Producer Statement is valid for a building consent issued within 1 year from the date of issue.**
- (x) **Inspections of the building are to be undertaken by the Building Consent Authority (council).**



New Zealand Institute of Architects Incorporated



I believe on reasonable grounds that a) the building, if constructed in accordance with the drawings, specifications, and other documents provided or listed in the attached schedule, will comply with the relevant provisions of the Building Code and that b), the persons who have undertaken the design have the necessary competency to do so. I also recommend the following level of construction monitoring/observation: (Refer note above)

CM1 CM2 CM3 CM4 CM5 (Engineering Categories) or as per agreement with owner/developer (Architectural)

I, **Craig Allan Manssen** am: CPEng **161576 #**

(Name of Design Professional)

Reg Arch #

I am a Member of: Engineering New Zealand NZIA and hold the following qualifications: **B.E.(Hons), CMEngNZ, CPEng**

The Design Firm issuing this statement holds a current policy of Professional Indemnity Insurance no less than \$200,000*.

The Design Firm is a member of ACENZ:

SIGNED BY **Craig Allan Manssen** ON BEHALF OF **Kirk Roberts Consulting Engineers Ltd.**

(Design Firm)

Digitally signed by C.A. Manssen
DN: C=NZ, E=craigm@kirkroberts.co.nz,
O=Kirk Roberts, OU=Kirk Roberts, CN=C
A.Manssen
Location: New Zealand
Reason: I am approving this document
Contact info: 0220993864
Date: 2025.08.14 14:53:39+1200

Date: **14 August 2025** (signature).....

Note: This statement shall only be relied upon by the Building Consent Authority named above. Liability under this statement accrues to the Design Firm only. The total maximum amount of damages payable arising from this statement and all other statements provided to the Building Consent Authority in relation to this building work, whether in contract, tort or otherwise (including negligence), is limited to the sum of \$200,000.*

This form is to accompany **Form 2 of the Building (Forms) Regulations 2004** for the application of a Building Consent.

THIS FORM AND ITS CONDITIONS ARE COPYRIGHT TO ACENZ, ENGINEERING NEW ZEALAND AND NZIA

VIBLOCK BRICK CLADDING SYSTEM – SPECIFICATION VB-B3

THREE-STOREY RUNNING BONDED SPECIFICATION

GENERAL

The following is a specification used for the construction of three-storey, running-bonded brick veneers.

- This document presents an ‘Alternative Solution’ to E2/AS1 applicable when Viblock concrete bricks, as mentioned in this document, are used as a masonry brick veneer.
- This document is to be read in accordance with the pre-requisite Viblock brick cladding system specification VB-B1 & VB-B2. Items not covered in this specification must comply with the specific design bricklaying specification for Viblock concrete bricks, Specification VB-B1.

Should a requirement in this document conflict with either VB-B1 or VB-B2, this specification, Specification VB-B3, is to apply.

LIMITATIONS

The designer shall ensure that Viblock brick veneer detailing, as presented within the Building Consent Plans and Specifications, complies with all aspects of this ‘Specific Design Specification’. Plans submitted for Building Consent must be clearly marked and identify the use of Viblock brick veneers as follows;

“Viblock Brick Cladding System – Specification VB-B3 – no substitution”

The Viblock three-storey running bonded brick veneer shall be subject to the limitations outlined in Specifications VB-B1 and VB-B2, with the following exceptions:

- Up to a 3kPa floor loading.
- A maximum of three-storey construction.
- Limited to a maximum calculated risk score of 20 in accordance with NZBC Acceptable Solution E2/AS1 Table 2.
- Where timber studs are used as the support structure, a maximum stud spacing of 400mm shall apply. Specific design of supporting structure for the upper level, beyond the limitations of NZS 3604 shall apply.
- Maximum veneer height of veneer above adjacent finished ground level of 10.0m for straight vertical panels and extended to 12.0m at the apex of a gable end or a pier of no more than 1.0m width.
- Installation of a mid-wall shelf angle at 6.0m, or at the structural floor level of the third storey floor (whichever is smaller), in accordance with Figure 2.
- Maximum veneer height of 10.0m for straight vertical panels and 12.0m to the apex of a gable or a pier as defined in this document, in accordance with Figure 1.

Bricks

Brick types for which this specification is applicable are as follows:

Table 1 – Bricks applicable to this specification

| Bricks applicable to this specification | | | | |
|---|------------------|-------------------|-----------------------|-----------------------------|
| Viblock Brick Product | Size (LxHxW) | No/m ² | Weight (kg) Per brick | Weight (kg/m ²) |
| Dunstan | 220 x 136 x 70mm | 32 | 3.6 | 125 |
| Shotover | 220 x 73 x 70mm | 56 | 1.9 | 120 |
| Hawea | 450 x 136 x 70mm | 16 | 7.2 | 120 |
| Wakatipu | 450 x 220 x 70mm | 10 | 11.5 | 118 |
| Viblock 10 Series | 390 x 190 x 90mm | 12.5 | 10.6 | 137 |
| Viblock 10 Series – Half High | 390 x 90 x 90mm | 25 | 4.8 | 128 |
| Viblock 10 Series - Fluted | 390 x 190 x 90mm | 12.5 | 12.5 | 160 |
| Viblock 10 Series - Split face | 390 x 190 x 90mm | 12.5 | 13.8 | 177 |
| Dart | 450 x 52 x 72mm | 40 | 3.25 | 130 |
| Kawarau | 450 x 70 x 70mm | 30 | 4.1 | 123 |
| Nevis 70 | 390 x 40 x 70mm | 50 | 2.45 | 125 |
| Nevis 95 | 390 x 40 x 95mm | 50 | 3.2 | 160 |

Note: Table 1 includes a 4% allowance for wastage in the number of bricks per m², for ordering purposes, add 15kg/m² for the addition of 10mm plaster finish.

BRICK VENEER CONSTRUCTION

Maximum Veneer Heights

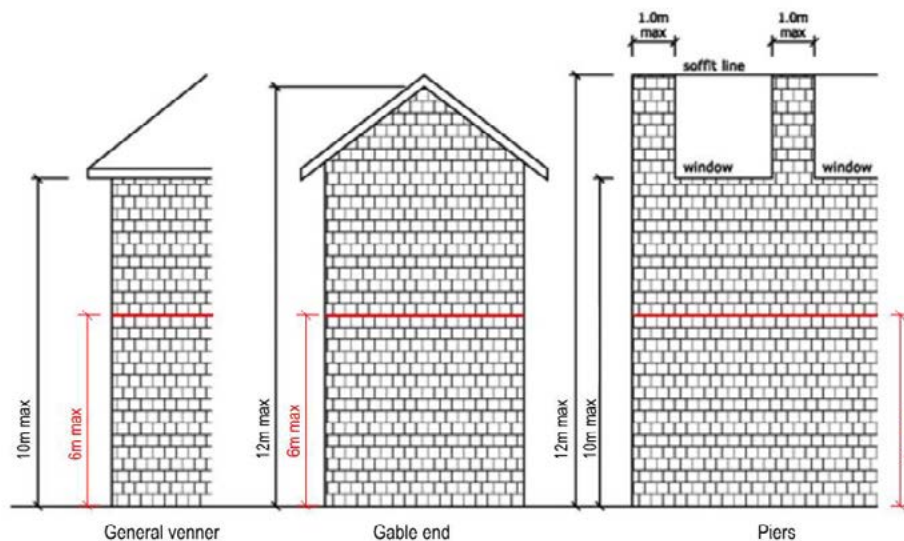

Figure 1 - Maximum Veneer Heights for three-storey running bond construction

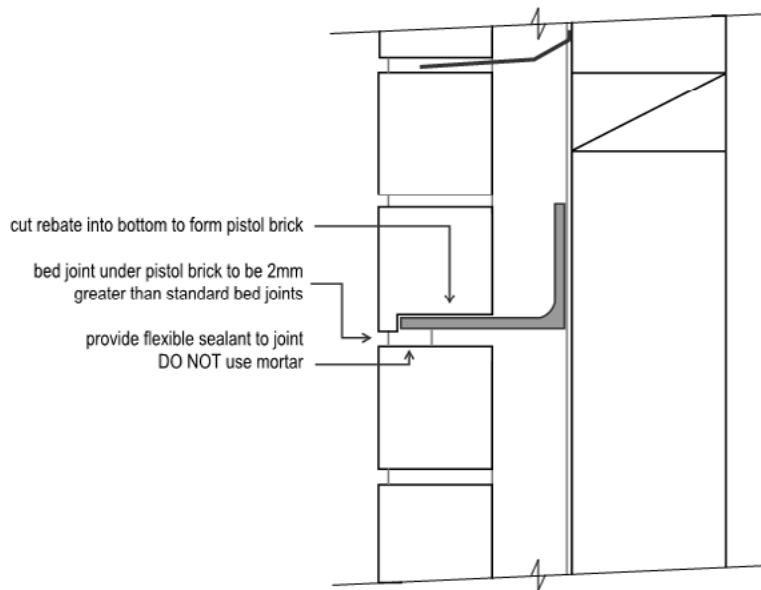

Figure 2 – Recommended hidden shelf angle detail

Wall Panels

- The bricks may be laid in one panel to a maximum height of 10m.
- Above 6m, or at the structural floor level of the third storey floor (whichever is the lesser), a mid-wall shelf angle is to be installed in accordance with Figure 2.
- The shelf angle is to be installed at all areas where the veneer panel extends above 6m, except where this is a gable or pier in accordance with specification VB-B2.
- The bed joint under the shelf angle is to be fill with a suitable flexible sealant, NOT mortar.
- The veneer panels below 6m are to be installed in accordance with specification VB-B2.

Gable Ends and Piers

- The brick veneer can be laid to a maximum height of 12.0m with a gable end.
- A pier is defined as a brick panel not exceeding 1.0m in width and not supporting a brick steel lintel in any way. A pier must not exceed 12m in height.

Supporting structure

- The supporting structure shall be timber framed construction in accordance with NZS 3604, concrete block/precast in accordance with NZS 4229 or light structural framing in accordance with NASH Standards part 1 and 2. Alternatively, or where support structure deviates from these codes a specific engineering designed supporting structure may be adopted. Supporting structure to be designed and detailed by a suitably qualified engineer.

Bracing

Bracing requirements of walls shall be calculated using the prescribed tables in NZS 3604, or where the building falls outside of the limitations of this code, by a suitably qualified engineer.

Brick Cavity

The cavity shall comply with the requirements noted in Specification VB-B1.

Brick Tie Installation

Brick ties shall comply with the requirements noted in Specification VB-B1 with the exception of the spacing requirements outlined below:

Brick tie spacing

Brick ties are to be fixed horizontally to supporting structure at a maximum spacing of 400mm, and vertically depending on the height of the brick as per table below. The upper most line of ties shall be installed at the first mortar bed joint from the top of the wall.

Table 2 – Tie spacing

| Placement of Brick ties in Mortar Courses | | |
|--|------------------------|---|
| Viblock Brick Product | Height of Brick | Horizontal fixings at 400mm crs. |
| Dunstan | 136mm | Every 2 nd course |
| Shotover | 73mm | Every 4 th course |
| Hawea | 136mm | Every 2 nd course |
| Wakatipu | 220mm | Every 2 nd course |
| Viblock 10 Series | 190mm | Every 2 nd course |
| Viblock 10 Series – Half High | 90mm | Every 4 th course |
| Viblock 10 Series - Fluted | 190mm | Every 2 nd course |
| Viblock 10 Series - Split face | 190mm | Every 2 nd course |
| Dart | 52mm | Every 6 th course |
| Kawarau | 70mm | Every 5 th course |
| Nevis 70 | 40mm | Every 6 th course |
| Nevis 95 | 40mm | Every 6 th course |

Joint Reinforcement

- Bed joint reinforcement below the mid wall shelf angle is to comply with the requirements set out in specification VB-B2.
- Above the mid-wall shelf angle, install one row of bed joint reinforcement, in the first bed joint of the panel.
- Install further rows of bed joint reinforcement, spaced 800mm ± 100mm apart above this level, including into gables where required.
- Bed joint reinforcement is not required within piers above the veneer panel.
- Install a final row of bed joint reinforcement in the second bed joint from the top of, except where a gable extends above, the panel.

Lintels

Lintels shall comply with the requirements noted in Specification VB-B1, with the following exceptions:

- Seated lintels may only be used over openings in the second and third level of a three-storey building.
- Seated lintels may not be used over a skirt roof (use of seated lintels over an opening above a skirt roof is permitted).

Shelf Angles

In addition to the requirements set out in Specification VB-B1, shelf angles may be installed above skirt roofs.

- The architect/engineer is to ensure an adequate support structure for fixing of the shelf angle.
- The maximum veneer panel height above a shelf angle over a skirt roof is to be 4m, measured as shown in Figure 3 below.

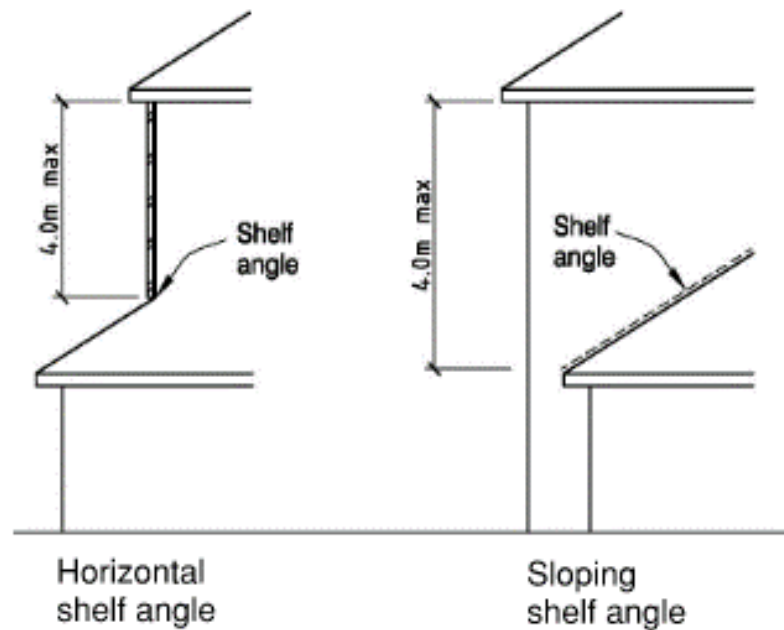

Figure 3 – Shelf Angles – diagram sourced from Clay Brick & Paver Manufactures association

TECHNICAL SUPPORT

Should you require any technical support on the Viblock Brick Veneer System, please contact Viblock on:

T: (03) 343 0394

Email: sales@viblock.co.nz

Website: <https://www.viblock.co.nz/contact-us/>



New Zealand
Institute of Architects
Incorporated



Building Code Clause(s) B1

PRODUCER STATEMENT – PS1 – DESIGN

ISSUE: 06

(Guidance on use of Producer Statements is available at www.engineeringnz.org)

ISSUED BY: **KIRK ROBERTS Consulting Ltd.**
(Design Firm) PROJECT NO: 2020853

TO: **Viblock**
(Owner/Developer)

TO BE SUPPLIED TO: **Relevant Territorial Authority**
(Building Consent Authority)

IN RESPECT OF: **Three-storey running bonded brick veneer specification as per the attached documentation**
'VIBLOCK BRICK CLADDING SYSTEM – SPECIFICATION VB-B3'
(Description of Building Work)

AT: **Locations throughout New Zealand**
(Address)

We have been engaged by the owner/developer referred to above to provide **Structural Engineering Design** services in respect of the requirements of Clause(s) **B1/VM1** of the Building Code for All or Part only (as specified in the attachment to this statement), of the proposed building work.

The design carried out by us has been prepared in accordance with:

- Compliance Documents issued by the Ministry of Business, Innovation & Employment **B1/VM1** or
(verification method / acceptable solution)
- Alternative solution as per the attached schedule: _____

The proposed building work covered by this producer statement is described on the attached specification titled **'VIBLOCK BRICK CLADDING SYSTEM – SPECIFICATION VB-B3 revF'** and dated **14th August 2025**

On behalf of the Design Firm, and subject to:

- (i) All proprietary products meeting their performance specification requirements.
- (ii) Up to **'Extra High'** wind zone in accordance with NZS3604: 2011.
- (iii) Maximum site hazard factor **Z = 0.4** in accordance with NZS1170.5: 2004.
- (iv) Structural design loads are based on a **50 year design life** and Importance **Level 2 structure** (normal structures and structures not in other importance levels) as defined in AS/NZS 1170.0 2004 clause 3.3.
- (v) Compliance with pre-requisite documents **'VIBLOCK BRICK CLADDING SYSTEM – SPECIFICATION VB-B1, & VB-B2'**
- (vi) Unless specifically noted, all structural elements must comply with the relevant New Zealand design code such as **NZS 3604, NZS 4229, NZS 2699, NZS 4210, and NZS HB 4236**.
These elements include, but are not limited to: **brick ties, mortar strength, brick strength, and bond between the brick and mortar.**
- (vii) Viblock brick products shall be manufactured to the requirements of **NZS 4455**.
- (viii) **This certificate does not cover weather-tightness, nor the stability, suitability or potential liquefaction of the site.**
- (ix) **This Producer Statement is valid for a building consent issued within 1 year from the date of issue.**
- (x) **Inspections of the building are to be undertaken by the Building Consent Authority (council).**



New Zealand Institute of Architects Incorporated



I believe on reasonable grounds that a) the building, if constructed in accordance with the drawings, specifications, and other documents provided or listed in the attached schedule, will comply with the relevant provisions of the Building Code and that b), the persons who have undertaken the design have the necessary competency to do so. I also recommend the following level of construction monitoring/observation: (Refer note above)

CM1 CM2 CM3 CM4 CM5 (Engineering Categories) or as per agreement with owner/developer (Architectural)

I, **Craig Allan Manssen** am: CPEng **161576 #**
(Name of Design Professional)

Reg Arch #

I am a Member of: Engineering New Zealand NZIA and hold the following qualifications: **B.E.(Hons), CMEngNZ, CPEng**
The Design Firm issuing this statement holds a current policy of Professional Indemnity Insurance no less than \$200,000*.
The Design Firm is a member of ACENZ:

SIGNED BY **Craig Allan Manssen** ON BEHALF OF **Kirk Roberts Consulting Engineers Ltd.**

Digitally signed by C A Manssen (Design Firm)
DN: C=NZ, E=craig@kirkroberts.co.nz,
O=Kirk Roberts, OU=Kirk Roberts, CN=C A
Manssen
Location: New Zealand
Reason: I am approving this document
Contact: T:022093854
Date: 2025.08.14 14:53:02+12'00'

Date: **14 August 2025** (signature).....

Note: This statement shall only be relied upon by the Building Consent Authority named above. Liability under this statement accrues to the Design Firm only. The total maximum amount of damages payable arising from this statement and all other statements provided to the Building Consent Authority in relation to this building work, whether in contract, tort or otherwise (including negligence), is limited to the sum of \$200,000.*

This form is to accompany **Form 2 of the Building (Forms) Regulations 2004** for the application of a Building Consent.

THIS FORM AND ITS CONDITIONS ARE COPYRIGHT TO ACENZ, ENGINEERING NEW ZEALAND AND NZIA

VIBLOCK STACK BONDED BRICK CLADDING SYSTEM – SPECIFICATION VB-S1 SINGLE-STOREY STACK BONDED SPECIFICATION

GENERAL

The following is a specification used for the construction of single-storey, stack-bonded brick veneers.

- This document presents an ‘Alternative Solution’ to E2/AS1 applicable when Viblock concrete bricks, as mentioned in this document, are used as a masonry brick veneer.
- This document is to be read in accordance with the pre-requisite Viblock brick cladding system specification VB-B1. Items not covered in this specification must comply with the specific design bricklaying specification for Viblock concrete bricks, Specification VB-B1.

Should a requirement in this document conflict with VB-B1, this specification, Specification VB – S1, is to apply.

LIMITATIONS

The designer shall ensure that Viblock brick veneer detailing, as presented within the Building Consent Plans and Specifications, complies with all aspects of this ‘Specific Design Specification’. Plans submitted for Building Consent must be clearly marked and identify the use of Viblock brick veneers as follows;

“Viblock Brick Cladding System – Specification VB-S1 – no substitution”

The Viblock single storey stack bonded brick veneer shall be subject to the limitations outlined in Specification VB-B1, with the following exceptions:

- Bricks must be laid in a stack bond pattern.
- Where timber studs are used as the support structure, a maximum stud spacing of 400mm shall apply.

Bricks

Brick types for which this specification is applicable are as follows:

Table 1 –Bricks applicable to this specification

| Bricks applicable to this specification | | | | |
|--|---------------------|-------------------------|----------------------------------|----------------------------------|
| Viblock Brick Product | Size (LxHxW) | No/m² | Weight (kg) Per brick | Weight (kg/m²) |
| Dunstan | 220 x 136 x 70mm | 32 | 3.6 | 125 |
| Shotover | 220 x 73 x 70mm | 56 | 1.9 | 120 |
| Hawea | 450 x 136 x 70mm | 16 | 7.2 | 120 |
| Wakatipu | 450 x 220 x 70mm | 10 | 11.5 | 118 |
| Viblock 10 Series | 390 x 190 x 90mm | 12.5 | 10.6 | 137 |
| Viblock 10 Series – Half High | 390 x 90 x 90mm | 25 | 4.8 | 128 |
| Viblock 10 Series - Fluted | 390 x 190 x 90mm | 12.5 | 12.5 | 160 |
| Viblock 10 Series - Split face | 390 x 190 x 90mm | 12.5 | 13.8 | 177 |
| Dart | 450 x 52 x 72mm | 40 | 3.25 | 130 |
| Kawarau | 450 x 70 x 70mm | 30 | 4.1 | 123 |
| Nevis 70 | 390 x 40 x 70mm | 50 | 2.45 | 125 |
| Nevis 95 | 390 x 40 x 95mm | 50 | 3.2 | 160 |

Note: Table 1 includes a 4% allowance for wastage in the number of bricks per m², for ordering purposes, add 15kg/m² for the addition of 10mm plaster finish.

BRICK VENEER CONSTRUCTION

Supporting structure

- The supporting structure shall be timber framed construction in accordance with NZS 3604, concrete block/precast in accordance with NZS 4229 or light structural framing in accordance with NASH Standards part 1 and 2. Alternatively, or where support structure deviates from these codes a specific engineering designed supporting structure may be adopted. Supporting structure to be designed and detailed by a suitably qualified engineer.

Brick Cavity

The cavity shall comply with the requirements noted in Specification VB-B1.

Brick Tie Installation

Brick ties shall comply with the requirements noted in Specification VB-B1, with the exception of the spacing requirements outlined below:

Brick tie spacing

Brick ties are to be fixed to supporting structure at a maximum horizontal spacing of 400mm, and vertically depending on the height of the brick as per table below. The upper most line of ties shall be installed at the first mortar bed joint below the top of the wall.

Table 2 – Tie spacing

| Placement of Brick ties in Mortar Courses | | |
|---|-----------------|----------------------------------|
| Viblock Brick Product | Height of Brick | Horizontal fixings at 400mm crs. |
| Dunstan Brick | 136mm | Every 4 th course |
| Shotover Brick | 73mm | Every 7 th course |
| Hawea | 136mm | Every 4 th course |
| Wakatipu | 220mm | Every 3 rd course |
| Viblock 10 Series | 190mm | Every 3 rd course |
| Viblock 10 Series – Half High | 90mm | Every 6 th course |
| Viblock 10 Series - Fluted | 190mm | Every 4 th course |
| Viblock 10 Series - Split face | 190mm | Every 4 th course |
| Dart | 52mm | Every 8 th Course |
| Kawarau | 70mm | Every 6 th Course |
| Nevis 70 | 40mm | Every 8 th course |
| Nevis 95 | 40mm | Every 8 th course |

Joint Reinforcement

- Bed joint reinforcement shall be installed in bed joints spaced at 800mm crs ± 100mm (depending on the brick height) over the height of the veneer.
- Bed joint reinforcement to be MASONS 4.0mm Bricklock STR and CNR galvanised or stainless-steel joint reinforcement or equivalent, as appropriate for the site exposure zone (refer NZS 3604).
- Bed joint reinforcement is to be placed in mortar joints that do not contain brick ties.

Due to the wide variety of designs, location of windows, panel widths, roof configurations etc., it is not practical to be more specific where consideration should be given to installing joint reinforcement. However, the following rules should be applied:

- Bed joint reinforcement to be installed within 350mm of the top and bottom of the panel.
- Bed joint reinforcement to be installed within 175mm of head and sill of window/door openings, extending minimum of 2 bricks into the adjacent brick panel.

Shelf Angles & Lintels

All shelf angles/lintels used for single storey stack bonded wall veneers are to comply with the relevant sections in Specification VB-B1.

TECHNICAL SUPPORT

Should you require any technical support on the Viblock stack-bonded Brick Veneer System, please contact Viblock on:

T: (03) 343 0394
Email: sales@viblock.co.nz
Website: <https://www.viblock.co.nz/contact-us/>



New Zealand
Institute of Architects
Incorporated



Building Code Clause(s) B1

PRODUCER STATEMENT – PS1 – DESIGN

ISSUE: 06

(Guidance on use of Producer Statements is available at www.engineeringnz.org)

ISSUED BY: **KIRK ROBERTS Consulting Ltd.**
(Design Firm) PROJECT NO: 2020853

TO: **Viblock**
(Owner/Developer)

TO BE SUPPLIED TO: **Relevant Territorial Authority**
(Building Consent Authority)

IN RESPECT OF: **Single storey stack bonded brick veneer specification as per the attached documentation**
'VIBLOCK BRICK CLADDING SYSTEM – SPECIFICATION VB-S1'
(Description of Building Work)

AT: **Locations throughout New Zealand**
(Address)

We have been engaged by the owner/developer referred to above to provide **Structural Engineering Design** services in respect of the requirements of Clause(s) **B1/VM1** of the Building Code for All or Part only (as specified in the attachment to this statement), of the proposed building work.

The design carried out by us has been prepared in accordance with:

- Compliance Documents issued by the Ministry of Business, Innovation & Employment **B1/VM1** or
(verification method / acceptable solution)
- Alternative solution as per the attached schedule: _____

The proposed building work covered by this producer statement is described on the attached specification titled **'VIBLOCK BRICK CLADDING SYSTEM – SPECIFICATION VB-S1 revF'** and dated **14th August 2025**

On behalf of the Design Firm, and subject to:

- (i) All proprietary products meeting their performance specification requirements.
- (ii) Up to **'Extra High'** wind zone in accordance with NZS3604: 2011.
- (iii) Maximum site hazard factor **Z = 0.4** in accordance with NZS1170.5: 2004.
- (iv) Structural design loads are based on a **50 year design life** and Importance **Level 2 structure** (normal structures and structures not in other importance levels) as defined in AS/NZS 1170.0 2004 clause 3.3.
- (v) Compliance with pre-requisite document **'VIBLOCK BRICK CLADDING SYSTEM – SPECIFICATION VB-B1'**
- (vi) Unless specifically noted, all structural elements must comply with the relevant New Zealand design code such as **NZS 3604, NZS 4229, NZS 2699, NZS 4210, and NZS HB 4236**.
These elements include, but are not limited to: **brick ties, mortar strength, brick strength, and bond between the brick and mortar.**
- (vii) Viblock brick products shall be manufactured to the requirements of **NZS 4455**.
- (viii) **This certificate does not cover weather-tightness, nor the stability, suitability or potential liquefaction of the site.**
- (ix) **This Producer Statement is valid for a building consent issued within 1 year from the date of issue.**
- (x) **Inspections of the building are to be undertaken by the Building Consent Authority (council).**



New Zealand Institute of Architects Incorporated



I believe on reasonable grounds that a) the building, if constructed in accordance with the drawings, specifications, and other documents provided or listed in the attached schedule, will comply with the relevant provisions of the Building Code and that b), the persons who have undertaken the design have the necessary competency to do so. I also recommend the following level of construction monitoring/observation: (Refer note above)

CM1 CM2 CM3 CM4 CM5 (Engineering Categories) or as per agreement with owner/developer (Architectural)

I, **Craig Allan Manssen** am: CPEng **161576 #**
(Name of Design Professional)

Reg Arch #

I am a Member of: Engineering New Zealand NZIA and hold the following qualifications: **B.E.(Hons), CMEngNZ, CPEng**
The Design Firm issuing this statement holds a current policy of Professional Indemnity Insurance no less than \$200,000*.
The Design Firm is a member of ACENZ:

SIGNED BY **Craig Allan Manssen** ON BEHALF OF **Kirk Roberts Consulting Engineers Ltd.**

(Design Firm)

Digitally signed by C A Manssen
DN: C=NZ, E=craigm@kirkroberts.co.nz,
OU=Kirk Roberts, OU=Kirk Roberts, CN=C
A Manssen
Location: New Zealand
Reason: I am approving this document
Contact info: 0220983884
Date: 2025.08.14.14:58:44+1200

Date: **14 August 2025** (signature).....

Note: This statement shall only be relied upon by the Building Consent Authority named above. Liability under this statement accrues to the Design Firm only. The total maximum amount of damages payable arising from this statement and all other statements provided to the Building Consent Authority in relation to this building work, whether in contract, tort or otherwise (including negligence), is limited to the sum of \$200,000.*

This form is to accompany **Form 2 of the Building (Forms) Regulations 2004** for the application of a Building Consent.

THIS FORM AND ITS CONDITIONS ARE COPYRIGHT TO ACENZ, ENGINEERING NEW ZEALAND AND NZIA

VIBLOCK STACK BONDED BRICK CLADDING SYSTEM – SPECIFICATION VB-S2

TWO-STOREY STACK BONDED SPECIFICATION

GENERAL

The following is a specification used for the construction of two-storey, stack-bonded brick veneers.

- This document presents an ‘Alternative Solution’ to E2/AS1 applicable when Viblock concrete bricks, as mentioned in this document, are used as a masonry brick veneer.
- This document is to be read in accordance with the pre-requisite Viblock brick cladding system specification VB-B1. Items not covered in this specification must comply with the specific design bricklaying specification for Viblock concrete bricks, Specification VB-B1.

Should a requirement in this document conflict with VB-B1, this specification, Specification VB – S2, is to apply.

LIMITATIONS

The designer shall ensure that Viblock brick veneer detailing, as presented within the Building Consent Plans and Specifications, complies with all aspects of this ‘Specific Design Specification’. Plans submitted for Building Consent must be clearly marked and identify the use of Viblock brick veneers as follows;

“Viblock Brick Cladding System – Specification VB-S2 – no substitution”

The Viblock two storey stack bonded brick veneer shall be subject to the limitations outlined in Specification VB-B1, VB-B2 and VB-S1 with the following exceptions:

- Bricks must be laid in a stack bond pattern.
- Where timber studs are used as the support structure, a maximum stud spacing of 400mm shall apply.
- Up to a 3kPa floor loading.
- A maximum of two-storey construction.
- Limited to a maximum calculated risk score of 20 in accordance with NZBC Acceptable Solution E2/AS1 Table 2.

Bricks

Brick types for which this specification is applicable are as follows:

Table 1 –Bricks applicable to this specification

| Bricks applicable to this specification | | | | |
|--|---------------------|-------------------------|----------------------------------|----------------------------------|
| Viblock Brick Product | Size (LxHxW) | No/m² | Weight (kg) Per brick | Weight (kg/m²) |
| Dunstan | 220 x 136 x 70mm | 32 | 3.6 | 125 |
| Shotover | 220 x 73 x 70mm | 56 | 1.9 | 120 |
| Hawea | 450 x 136 x 70mm | 16 | 7.2 | 120 |
| Wakatipu | 450 x 220 x 70mm | 10 | 11.5 | 118 |
| Viblock 10 Series | 390 x 190 x 90mm | 12.5 | 10.6 | 137 |
| Viblock 10 Series – Half High | 390 x 90 x 90mm | 25 | 4.8 | 128 |
| Viblock 10 Series - Fluted | 390 x 190 x 90mm | 12.5 | 12.5 | 160 |
| Viblock 10 Series - Split face | 390 x 190 x 90mm | 12.5 | 13.8 | 177 |
| Dart | 450 x 52 x 72mm | 40 | 3.25 | 130 |
| Kawarau | 450 x 70 x 70mm | 30 | 4.1 | 123 |
| Nevis 70 | 390 x 40 x 70mm | 50 | 2.45 | 125 |
| Nevis 95 | 390 x 40 x 95mm | 50 | 3.2 | 160 |

Note: Table 1 includes a 4% allowance for wastage in the number of bricks per m², for ordering purposes, add 15kg/m² for the addition of 10mm plaster finish.

BRICK VENEER CONSTRUCTION

Maximum Veneer Heights

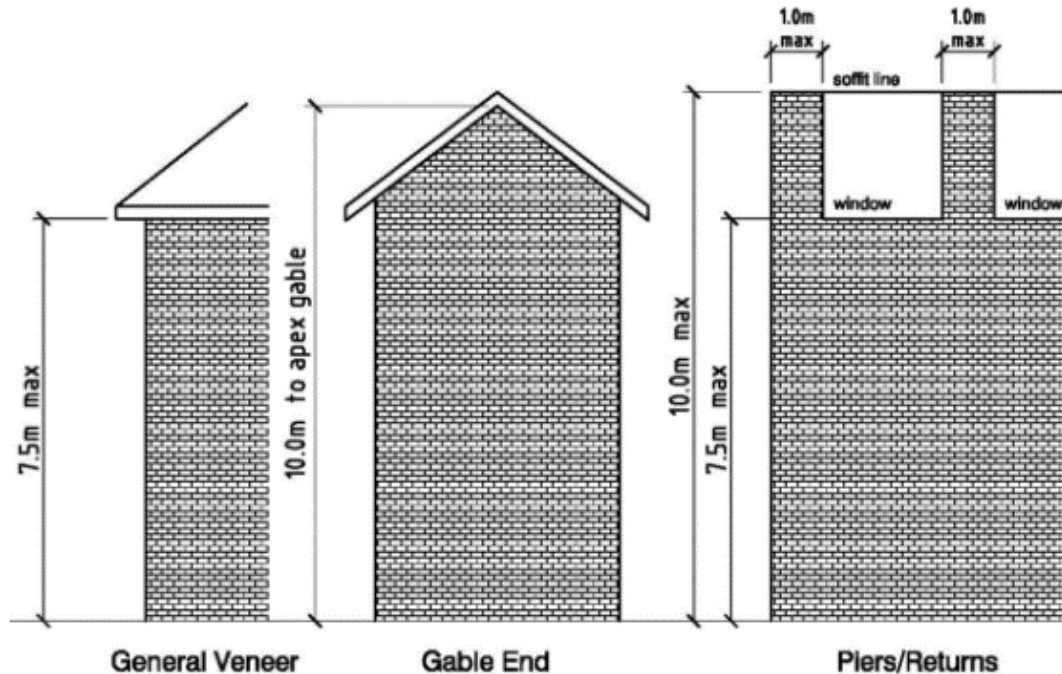

Figure 1 – Maximum Veneer Heights for two-storey stack bond construction – diagram sourced from Clay Brick & Paver Manufactures association

Wall Panels

- Brick wall panels may be laid to a maximum height of 7.5m without the addition of shelf angles or slip joints.

Gable Ends and Piers

- Gable end wall panels may be laid to a maximum height of 10m.
- Brick piers, of maximum width not exceeding 1.0m in width and not supporting loads from lintel shelf angles are not to exceed 10m in total height.

Supporting structure

- The supporting structure shall be timber framed construction in accordance with NZS 3604, concrete block/precast in accordance with NZS 4229 or light structural framing in accordance with NASH Standards part 1 and 2. Alternatively, or where support structure deviates from these codes a specific engineering designed supporting structure may be adopted. Supporting structure to be designed and detailed by a suitably qualified engineer.

Brick Cavity

The cavity shall comply with the requirements noted in Specification VB-B1.

Brick Tie Installation

Brick ties shall comply with the requirements noted in Specification VB-B1, with the exception of the spacing requirements outlined below:

Brick tie spacing

Brick ties are to be fixed to supporting structure at a maximum horizontal spacing of 400mm, and vertically depending on the height of the brick as per table below. The upper most line of ties shall be installed at the first mortar bed joint below the top of the wall.

Table 2 – Ties spacing

| Placement of Brick ties in Mortar Courses | | |
|---|-----------------|----------------------------------|
| Viblock Brick Product | Height of Brick | Horizontal fixings at 400mm crs. |
| Dunstan | 136mm | Every 3 rd course |
| Shotover | 73mm | Every 5 th course |
| Hawea | 136mm | Every 3 rd course |
| Wakatipu | 220mm | Every 2 nd course |
| Viblock 10 Series | 190mm | Every 2 nd course |
| Viblock 10 Series – Half High | 90mm | Every 5 th course |
| Viblock 10 Series - Fluted | 190mm | Every 2 nd course |
| Viblock 10 Series - Split face | 190mm | Every 2 nd course |
| Dart | 52mm | Every 8 th course |
| Kawarau | 70mm | Every 6 th course |
| Nevis 70 | 40mm | Every 8 th course |
| Nevis 95 | 40mm | Every 8 th Course |

Joint Reinforcement

- Install one row of bed joint reinforcement at 4m ± 100mm above the bottom course.
- Install further rows of bed joint reinforcement, spaced 800mm ± 100mm apart, above this level.
- Bed joint reinforcement is to be placed in mortar joints that do not contain brick ties.
- Bed joint reinforcement to be MASONS 4.0mm Bricklock STR and CNR galvanised or stainless-steel joint reinforcement or equivalent, as appropriate for the site exposure zone (refer NZS 3604).
- Where a gable exists on top of the veneer panel, install a further two rows of bed joint reinforcement, at the same spacing, into the gable.
- Bed joint reinforcement is not required within piers above the veneer panel.
- Bed joint reinforcement to be installed within 350mm of the top and bottom of the panel.
- Bed joint reinforcement to be installed within 175mm of head and sill of window/door openings, extending minimum of 2 bricks into the adjacent brick panel.

Due to the wide variety of designs, location of windows, panel widths, roof configurations etc., it is not practical to be more specific where consideration should be given to installing joint reinforcement.

Lintels

Lintels shall comply with the requirements noted in Specification VB-B1, with the following exceptions:

- Seated lintels may only be used over openings in the upper level of a two-storey building.
- Seated lintels may not be used over a skirt roof (use of seated lintels over an opening above a skirt roof is permitted).

Shelf Angles

In addition to the requirements set out in Specification VB-B1, shelf angles may be installed above skirt roofs.

- The architect/engineer is to ensure an adequate support structure for fixing of the shelf angle.
- The maximum veneer panel height above a shelf angle over a skirt roof is to be 4m, measured as shown in Figure 2 below.

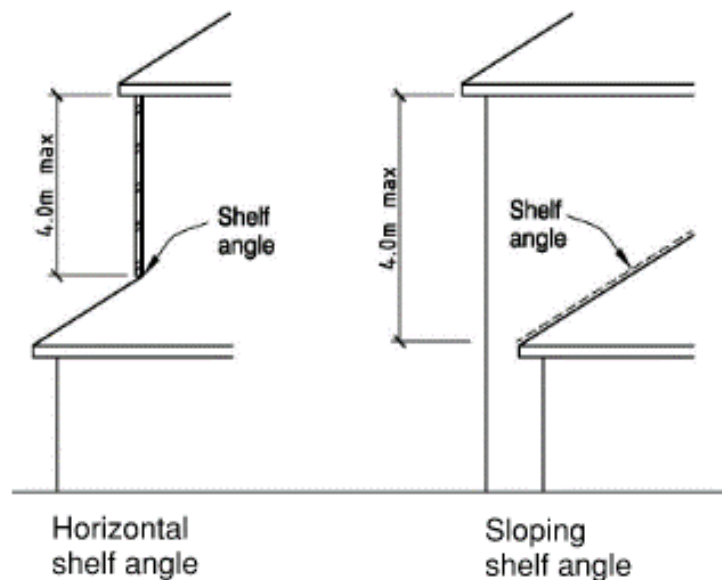

Figure 2 – Shelf Angles– diagram sourced from Clay Brick & Paver Manufactures association

TECHNICAL SUPPORT

Should you require any technical support on the Viblock Brick Veneer System, please contact Viblock on:

T: (03) 343 0394

Email: sales@viblock.co.nz

Website: <https://www.viblock.co.nz/contact-us/>



New Zealand
Institute of Architects
Incorporated



Building Code Clause(s) B1

PRODUCER STATEMENT – PS1 – DESIGN

ISSUE: 06

(Guidance on use of Producer Statements is available at www.engineeringnz.org)

ISSUED BY: **KIRK ROBERTS Consulting Ltd.**
(Design Firm) PROJECT NO: 2020853

TO: **Viblock**
(Owner/Developer)

TO BE SUPPLIED TO: **Relevant Territorial Authority**
(Building Consent Authority)

IN RESPECT OF: **Two-storey stack bonded brick veneer specification as per the attached documentation**
'VIBLOCK BRICK CLADDING SYSTEM – SPECIFICATION VB-S2'
(Description of Building Work)

AT: **Locations throughout New Zealand**
(Address)

We have been engaged by the owner/developer referred to above to provide **Structural Engineering Design** services in respect of the requirements of Clause(s) **B1/VM1** of the Building Code for All or Part only (as specified in the attachment to this statement), of the proposed building work.

The design carried out by us has been prepared in accordance with:

- Compliance Documents issued by the Ministry of Business, Innovation & Employment **B1/VM1** or
(verification method / acceptable solution)
- Alternative solution as per the attached schedule: _____

The proposed building work covered by this producer statement is described on the attached specification titled **'VIBLOCK BRICK CLADDING SYSTEM – SPECIFICATION VB-S2 revF'** and dated **14th August 2025**

On behalf of the Design Firm, and subject to:

- (i) All proprietary products meeting their performance specification requirements.
- (ii) Up to **'Extra High'** wind zone in accordance with NZS3604: 2011.
- (iii) Maximum site hazard factor **Z = 0.4** in accordance with NZS1170.5: 2004.
- (iv) Structural design loads are based on a **50 year design life** and Importance **Level 2 structure** (normal structures and structures not in other importance levels) as defined in AS/NZS 1170.0 2004 clause 3.3.
- (v) Compliance with pre-requisite documents **'VIBLOCK BRICK CLADDING SYSTEM – SPECIFICATION VB-B1, & VB-S1'**
- (vi) Unless specifically noted, all structural elements must comply with the relevant New Zealand design code such as **NZS 3604, NZS 4229, NZS 2699, NZS 4210, and NZS HB 4236**.
These elements include, but are not limited to: **brick ties, mortar strength, brick strength, and bond between the brick and mortar.**
- (vii) Viblock brick products shall be manufactured to the requirements of **NZS 4455**.
- (viii) **This certificate does not cover weather-tightness, nor the stability, suitability or potential liquefaction of the site.**
- (ix) **This Producer Statement is valid for a building consent issued within 1 year from the date of issue.**
- (x) **Inspections of the building are to be undertaken by the Building Consent Authority (council).**



New Zealand Institute of Architects Incorporated



I believe on reasonable grounds that a) the building, if constructed in accordance with the drawings, specifications, and other documents provided or listed in the attached schedule, will comply with the relevant provisions of the Building Code and that b), the persons who have undertaken the design have the necessary competency to do so. I also recommend the following level of construction monitoring/observation: (Refer note above)

CM1 CM2 CM3 CM4 CM5 (Engineering Categories) or as per agreement with owner/developer (Architectural)

I, **Craig Allan Manssen** am: CPEng **161576 #**

(Name of Design Professional)

Reg Arch #

I am a Member of: Engineering New Zealand NZIA and hold the following qualifications: **B.E.(Hons), CMEngNZ, CPEng**

The Design Firm issuing this statement holds a current policy of Professional Indemnity Insurance no less than \$200,000*.

The Design Firm is a member of ACENZ:

SIGNED BY **Craig Allan Manssen** ON BEHALF OF **Kirk Roberts Consulting Engineers Ltd.**

(Design Firm)

Digitally signed by C A Manssen
DN: C=NZ, E=craigm@kirkroberts.co.nz,
O=Kirk Roberts, OU=Kirk Roberts, CN=C
A.Manssen
Location: New Zealand
Reason: I am approving this document
Contact info: 0220993864
Date: 2025.08.14.14:52:56+12'00'

Date: **14 August 2025** (signature).....

Note: This statement shall only be relied upon by the Building Consent Authority named above. Liability under this statement accrues to the Design Firm only. The total maximum amount of damages payable arising from this statement and all other statements provided to the Building Consent Authority in relation to this building work, whether in contract, tort or otherwise (including negligence), is limited to the sum of \$200,000*.

This form is to accompany **Form 2 of the Building (Forms) Regulations 2004** for the application of a Building Consent.

THIS FORM AND ITS CONDITIONS ARE COPYRIGHT TO ACENZ, ENGINEERING NEW ZEALAND AND NZIA

VIBLOCK STACK BONDED BRICK CLADDING SYSTEM – SPECIFICATION VB-S3

THREE-STOREY STACK BONDED SPECIFICATION

GENERAL

The following is a specification used for the construction of two-storey, running-bonded brick veneers.

- This document presents an ‘Alternative Solution’ to E2/AS1 applicable when Viblock concrete bricks, as mentioned in this document, are used as a masonry brick veneer.
- This document is to be read in accordance with the pre-requisite Viblock brick cladding system specification VB-B1 & VB-B2. Items not covered in this specification must comply with the specific design bricklaying specification for Viblock concrete bricks, Specification VB-B1.

Should a requirement in this document conflict with either VB-S1 or VB-S2, this specification, Specification VB – S3, is to apply.

LIMITATIONS

The designer shall ensure that Viblock brick veneer detailing, as presented within the Building Consent Plans and Specifications, complies with all aspects of this ‘Specific Design Specification’. Plans submitted for Building Consent must be clearly marked and identify the use of Viblock brick veneers as follows;

“Viblock Brick Cladding System – Specification VB-S3 – no substitution”

The Viblock three-storey stack bonded brick veneer shall be subject to the limitations outlined in Specifications VB-B1, VB-S1, and VB-S2 with the following exceptions:

- Brick must be laid in a stack bonded pattern.
- Up to a 3kPa floor loading.
- A maximum of three-storey construction.
- Limited to a maximum calculated risk score of 20 in accordance with NZBC Acceptable Solution E2/AS1 Table 2.
- Where timber studs are used as the support structure, a maximum stud spacing of 400mm shall apply. Specific design of supporting structure for the upper level, beyond the limitations of NZS 3604 shall apply.
- Maximum veneer height of veneer above adjacent finished ground level of 10.0m for straight vertical panels and extended to 12.0m at the apex of a gable end or a pier of no more than 1.0m width.
- Installation of a mid-wall shelf angle at 6.0m, or at the structural floor level of the third storey floor (whichever is smaller), in accordance with Figure 2.
- Maximum veneer height of 10.0m for straight vertical panels and 12.0m to the apex of a gable or a pier as defined in this document, in accordance with Figure 1.

Bricks

Brick types for which this specification is applicable are as follows:

Table 1 – Bricks applicable to this specification

| Bricks applicable to this specification | | | | |
|---|------------------|-------------------|-----------------------|-----------------------------|
| Viblock Brick Product | Size (LxHxW) | No/m ² | Weight (kg) Per brick | Weight (kg/m ²) |
| Dunstan | 220 x 136 x 70mm | 32 | 3.6 | 125 |
| Shotover | 220 x 73 x 70mm | 56 | 1.9 | 120 |
| Hawea | 450 x 136 x 70mm | 16 | 7.2 | 120 |
| Wakatipu | 450 x 220 x 70mm | 10 | 11.5 | 118 |
| Viblock 10 Series | 390 x 190 x 90mm | 12.5 | 10.6 | 137 |
| Viblock 10 Series – Half High | 390 x 90 x 90mm | 25 | 4.8 | 128 |
| Viblock 10 Series - Fluted | 390 x 190 x 90mm | 12.5 | 12.5 | 160 |
| Viblock 10 Series - Split face | 390 x 190 x 90mm | 12.5 | 13.8 | 177 |
| Dart | 450 x 52 x 72mm | 40 | 3.25 | 130 |
| Kawarau | 450 x 70 x 70mm | 30 | 4.1 | 123 |
| Nevis 70 | 390 x 40 x 70mm | 50 | 2.45 | 125 |
| Nevis 95 | 390 x 40 x 95mm | 50 | 3.2 | 160 |

Note: Table 1 includes a 4% allowance for wastage in the number of bricks per m², for ordering purposes, add 15kg/m² for the addition of 10mm plaster finish.

BRICK VENEER CONSTRUCTION

Maximum Veneer Heights

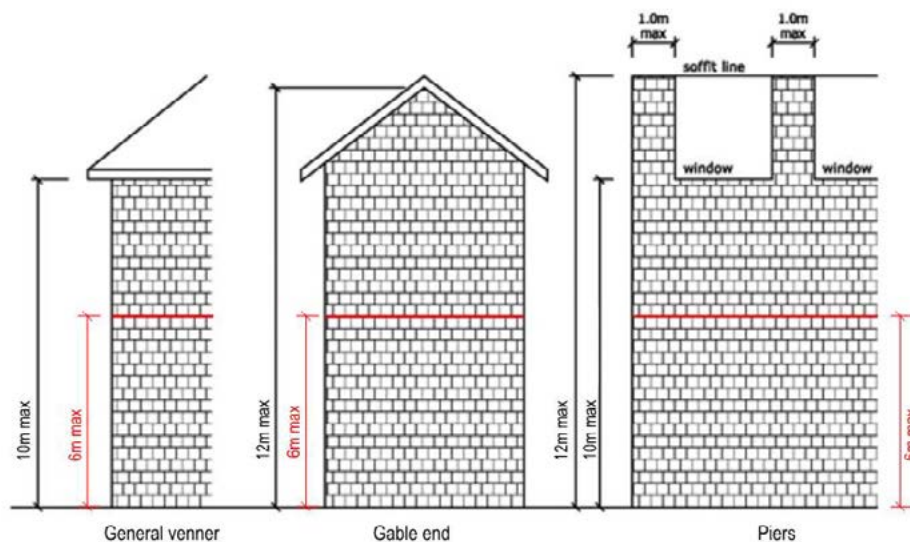

Figure 1 - Maximum Veneer Heights for three-storey stack bond construction

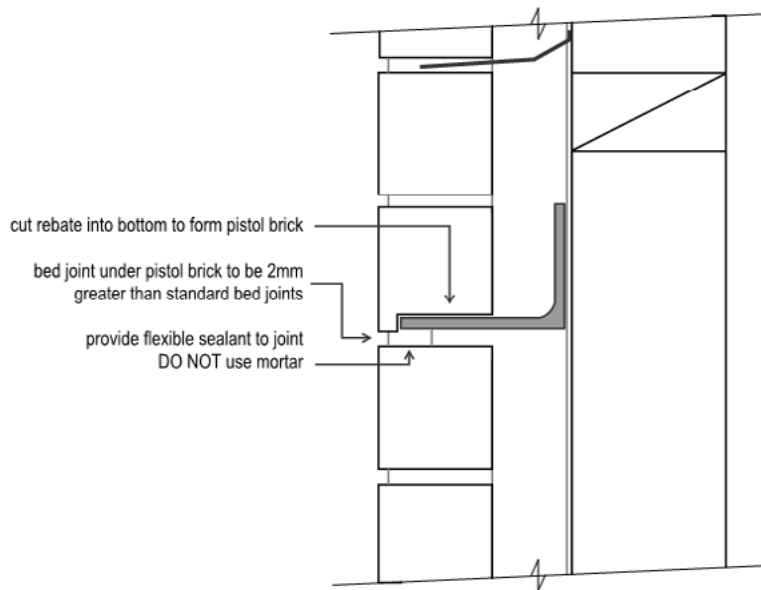

Figure 2 – Recommended hidden shelf angle detail

Wall Panels

- The bricks may be laid in one panel to a maximum height of 10m.
- Above 6m, or at the structural floor level of the third storey floor (whichever is the lesser), a mid-wall shelf angle is to be installed in accordance with Figure 2.
- The shelf angle is to be installed at all areas where the veneer panel extends above 6m, except where this is a gable or pier in accordance with specification VB-S2.
- The bed joint under the shelf angle is to be fill with a suitable flexible sealant, NOT mortar.
- The veneer panels below 6m are to be installed in accordance with specification VB-S2.

Gable Ends and Piers

- The brick veneer can be laid to a maximum height of 12.0m with a gable end.
- A pier is defined as a brick panel not exceeding 1.0m in width and not supporting a brick steel lintel in any way. A pier must not exceed 12m in height.

Supporting structure

- The supporting structure shall be timber framed construction in accordance with NZS 3604, concrete block/precast in accordance with NZS 4229 or light structural framing in accordance with NASH Standards part 1 and 2. Alternatively, or where support structure deviates from these codes a specific engineering designed supporting structure may be adopted. Supporting structure to be designed and detailed by a suitably qualified engineer.

Bracing

Bracing requirements of walls shall be calculated using the prescribed tables in NZS 3604, or where the building falls outside of the limitations of this code, by a suitably qualified engineer.

Brick Cavity

The cavity shall comply with the requirements noted in Specification VB-S1.

Brick Tie Installation

Brick ties shall comply with the requirements noted in Specification VB-S1 with the exception of the spacing requirements outlined below:

Brick tie spacing

Brick ties are to be fixed horizontally to supporting structure at a maximum spacing of 400mm, and vertically depending on the height of the brick as per table below. The upper most line of ties shall be installed at the first mortar bed joint from the top of the wall.

Table 2 – Tie spacing

| Placement of Brick ties in Mortar Courses | | |
|---|-----------------|------------------------------|
| Viblock Brick Product | Height of Brick | Studs at 400mm crs. |
| Dunstan | 136mm | Every 2 nd course |
| Shotover | 73mm | Every 4 th course |
| Hawea | 136mm | Every 2 nd course |
| Wakatipu | 220mm | Every 2 nd course |
| Viblock 10 Series | 190mm | Every 2 nd course |
| Viblock 10 Series – Half High | 90mm | Every 4 th course |
| Viblock 10 Series - Fluted | 190mm | Every 2 nd course |
| Viblock 10 Series - Split face | 190mm | Every 2 nd course |
| Dart | 52mm | Every 6 th course |
| Kawarau | 70mm | Every 5 th course |
| Nevis 70 | 40mm | Every 6 th course |
| Nevis 95 | 40mm | Every 6 th course |

Joint Reinforcement

- Bed joint reinforcement across the brick veneer is to comply with the requirements set out in specification VB-S2.

Lintels

Lintels shall comply with the requirements noted in Specification VB-S1, with the following exceptions:

- Seated lintels may only be used over openings in the second and third level of a three-storey building.
- Seated lintels may not be used over a skirt roof (use of seated lintels over an opening above a skirt roof is permitted).

Shelf Angles

In addition to the requirements set out in Specification VB-S1, shelf angles may be installed above skirt roofs.

- The architect/engineer is to ensure an adequate support structure for fixing of the shelf angle.
- The maximum veneer panel height above a shelf angle over a skirt roof is to be 4m, measured as shown in Figure 3 below.

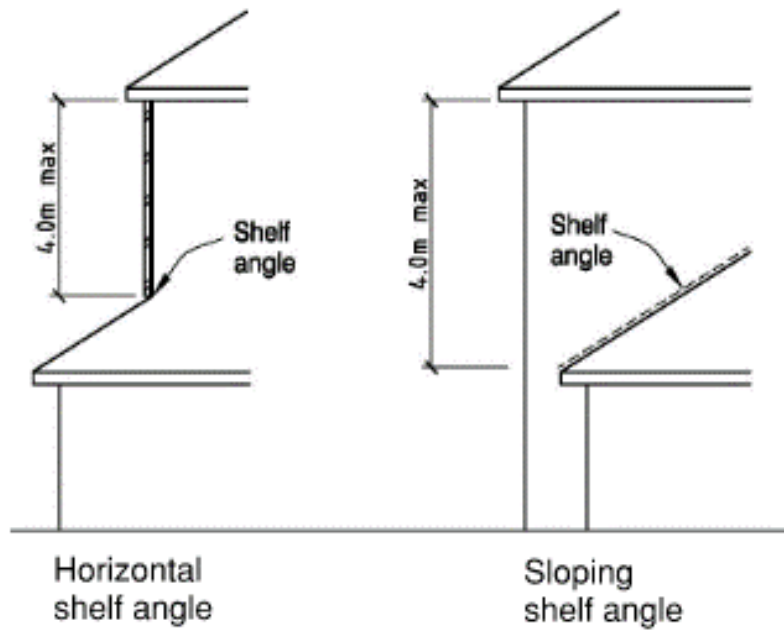

Figure 3 – Shelf Angles– diagram sourced from Clay Brick & Paver Manufactures association

TECHNICAL SUPPORT

Should you require any technical support on the Viblock Brick Veneer System, please contact Viblock on:

T: (03) 343 0394

Email: sales@viblock.co.nz

Website: <https://www.viblock.co.nz/contact-us/>

